

OPERATOR: ED-WES, INC.

REPORT DATE 09/16/91

WORK COMPLIANCE FORM NO.

95.090

AIRCRAFT NO.: 368

MODEL: 1124A WESTWIND

OPER01

AIRCRAFT REG.: N368MD

050150+ 150 HR INSPECTION

RECORD TIME WORK ACCOMPLISHED FOR EACH TASK. KEEP TOP COPY FOR YOUR RECORDS. RETURN CARBON COPY TO CSI FOR UPDATING.

91259
95-001
29 29

WORK DUE AT		* = APU HRS	
DATE	HOURS	LANDINGS	CYCLES
	5028		

CK CURRENT DUE LIST FOR DUE TIME CHGS

PAGE 1

WORK ACCOMPLISHED: DATE: MONTH 1 DAY 22 YEAR 92 AIRCRAFT HOURS: 5028.8 LANDINGS: 3654

TECHNICIAN SIGNATURE: Alan Hecox CERTIFICATE NUMBER: 542049527

INSPECTED BY: G. O. Duvall KIND OF CERTIFICATE: _____

TECHNICIAN	INSPECTOR	MAN-HOURS
		HRS. THS

DA

950920 SERVICE LETTER WW-2492 HYDRAULIC HOSE INSPECTION...SL WW-2492.....

REASON: REMIND PERSONNEL OF THE LEAK INSPECTION REQUIREMENTS FOR ALL HYDRAULIC SYSTEM HOSES AND TO PAY SPECIAL ATTENTION TO THOSE THAT CONTAIN A RUBBER LINER MATERIAL (COLOR CODED BY A GREEN EXTERNAL APPEARANCE).

INSTRUCTIONS: ROUTINE INSPECTION SHOULD BE PERFORMED OF ALL HYDRAULIC SYSTEM FLEXIBLE HOSES FOR LEAKAGE OR DETERIORATION IN ACCORDANCE WITH THE REQUIREMENTS OF CHAPTER 5 OR 50 HOUR PHASE INSPECTION PROGRAM. MATERIALS USED IN TEFLON LINED HOSES ARE MORE RESISTANT TO WEAR AND DETERIORATION THAN THE RUBBER LINER HOSES. EITHER TYPE HOSE MAY BE USED OR REPLACEMENT OF DEFECTIVE HOSES, HOWEVER, THE TEFLON LINED HOSES SHOULD PROVIDE EXTENDED SERVICE LIFE.

REFER TO APPLICABLE SERVICE LETTER FOR PROCEDURE.

OPERATOR: ED-WES, INC.

REPORT DATE 11/12/91

WORK COMPLIANCE FORM NO.

25.050

AIRCRAFT NO.: 368

MODEL: 1124A WESTWIND

AIRCRAFT REG.: N368MD

ISSUED 07-88 REV.

PAGE 1

91316

WORK DUE AT

* = APU HRS

RECORD TIME WORK ACCOMPLISHED FOR EACH TASK. KEEP TOP COPY FOR YOUR RECORDS. RETURN CARBON COPY TO CSI FOR UPDATING.

00-000

DATE

HOURS

LANDINGS

CYCLES

29 29

01/10/92

CHECK CURRENT DUE LIST FOR DUE TIME CHANGES

WORK ACCOMPLISHED: DATE: MONTH 01 DAY 22 YEAR 92 AIRCRAFT HOURS: 5020.8 LANDINGS: 3654

TECHNICIAN SIGNATURE: Patrick M. Moffatt CERTIFICATE NUMBER: _____

INSPECTED BY: J.D. York KIND OF CERTIFICATE: _____

THE FOLLOWING WORK IS DUE AT THE TIME(S) NOTED ABOVE:

TECHNICIAN

INSPECTOR

MAN-HOURS

HRS. THS

250156 INSPECT LIFE PRESERVER...NO REF..... PH _____

NO TEXT AVAILABLE AT THIS TIME.

3 EA LIFE VEST IN CABIN

TYPE K&D-35

S/N 88838

F 34166

F 34347

ALL OH'D JAN 15 '92

OPERATOR: ED-WES, INC.

REPORT DATE 09/13/91

WORK COMPLIANCE FORM NO.

960078

AIRCRAFT NO.: 368

MODEL: 1124A WESTWIND

AIRCRAFT REG.: N368MD

PAGE 1

91256
90-001
29 29

WORK DUE AT DATE	HOURS	* = APU HRS LANDINGS	CYCLES
	3028		

RECORD TIME WORK ACCOMPLISHED FOR EACH TASK. KEEP TOP COPY FOR YOUR RECORDS. RETURN CARBON COPY TO CSI FOR UPDATING.

CHECK CURRENT DUE LIST FOR DUE TIME CHANGES

WORK ACCOMPLISHED: DATE: MONTH Jan DAY 22 YEAR 99 AIRCRAFT HOURS: 5020.8 LANDINGS: 3654

TECHNICIAN SIGNATURE: Marvin Goodidge CERTIFICATE NUMBER: _____

INSPECTED BY: [Signature] KIND OF CERTIFICATE: _____

THE FOLLOWING WORK IS DUE AT THE TIME(S) NOTED ABOVE:

TECHNICIAN	INSPECTOR	MAN-HOURS HRS. THS
------------	-----------	-----------------------

960078 SIL 1124-21-078 REVISION 1 35 DEGREE TEMP SENSOR...SIL 1124-21-078..... MC

REASON: TO REDUCE THE EFFECTS OF DISSIMILAR METAL CORROSION ON THE CONTACTS OF TEMP SENSOR CONNECTOR, P/J116 AND ENSURE A MORE POSITIVE ELECTRICAL CONNECTION.

EFFECTIVITY: MODEL 1124/1124A WESTWIND, ALL SERIAL NUMBERS.

REFER TO APPLICABLE SERVICE BULLETIN FOR PROCEDURE.

OPERATOR: ED-WEB, INC.

REPORT DATE 06/13/91

WORK COMPLIANCE FORM NO.

99.010

AIRCRAFT NO.: 368

MODEL: 1124A WESTWIND

AIRCRAFT REG.: N368ND

PAGE 1

91164

WORK DUE AT

* = APU HRS.

RECORD TIME WORK ACCOMPLISHED FOR EACH TASK. KEEP TOP COPY FOR YOUR RECORDS. RETURN CARBON COPY TO CSI FOR UPDATING.

99-002

DATE

HOURS

LANDINGS

CYCLES

29 29

4989

CHECK CURRENT DUE LIST FOR DUE TIME CHANGES

WORK ACCOMPLISHED: DATE: MONTH 01 DAY 22 YEAR 92 AIRCRAFT HOURS: 5020.8 LANDINGS: 3654

TECHNICIAN SIGNATURE: Patrick M. Halbur CERTIFICATE NUMBER: _____

INSPECTED BY: L O Donnell KIND OF CERTIFICATE: _____

THE FOLLOWING WORK IS DUE AT THE TIME(S) NOTED ABOVE:

TECHNICIAN INSPECTOR MAN-HOURS
HRS.THS

990020 INSPECT LAVATORY DOORS...AD 74-08-09..... P.H. _____

990020

INSPECT LAVATORY DOORS

1. INSPECT ALL LAVATORY PAPER AND LINEN WASTE RECEPTACLE ENCLOSURE ACCESS DOORS AND DISPOSAL DOORS FOR PROPER OPERATION, FIT, SEALING, AND LATCHING FOR THE CONTAINMENT OF POSSIBLE TRACH FIRES AND CORRECT ALL DEFECTS FOUND.
2. RECORD INSPECTION COMPLIED WITH IN SPACE PROVIDED ON PAGE 1.

OPERATOR: ED-WES, INC.
 AIRCRAFT NO.: 368
 AIRCRAFT REG.: N368MD

REPORT DATE 09/13/91
 MODEL: 1124A WESTWIND

WORK COMPLIANCE FORM NO. 990985

PAGE 1

91256 99-001 29 29	WORK DUE AT			
	DATE	HOURS	LANDINGS	CYCLES
		5028		

RECORD TIME WORK ACCOMPLISHED FOR EACH TASK. KEEP TOP COPY FOR YOUR RECORDS. RETURN CARBON COPY TO CSI FOR UPDATING.

CHECK CURRENT DUE LIST FOR DUE TIME CHANGES

WORK ACCOMPLISHED: DATE: MONTH 1 DAY 23 YEAR 92 AIRCRAFT HOURS: 5020.8 LANDINGS: 3654

TECHNICIAN SIGNATURE: [Signature] CERTIFICATE NUMBER: _____

INSPECTED BY: [Signature] KIND OF CERTIFICATE: _____

THE FOLLOWING WORK IS DUE AT THE TIME(S) NOTED ABOVE:

TECHNICIAN	INSPECTOR	MAN-HOURS
HRS.	HRS.	THS
<u>ETP</u>	<u>ME</u>	

990985 AD 90-10-04 INSPECT LEFT HAND AILERON CONTROL ROD.....

REASON: TO DETECT CORROSION IN THE AILERON CONTROL ROD ASSEMBLY, ACCOMPLISH THE FOLLOWING:

COMPLIANCE: WITHIN 20 HOURS TIME-IN-SERVICE AFTER THE EFFECTIVE DATE OF THIS AD, AND THEREAFTER AT INTERVALS NOT TO EXCEED 130 HOURS TIME-IN-SERVICE, PERFORM A DETAILED VISUAL INSPECTION TO DETECT EVIDENCE OF CORROSION, SUCH AS PITS, AND/OR BLISTERS UNDER THE PAINT, ON THE LOWER EXTERIOR SURFACE OF THE AILERON TORQUE TRANSFER TUBES, IN ACCORDANCE WITH WESTWIND ASTRA SERVICE BULLETINS 1124-27-100, REVISION 1.

REFER TO APPLICABLE AIRWORTHINESS DIRECTIVE FOR PROCEDURE.

OPERATOR: ED-WES, INC.

REPORT DATE 09/13/91

WORK COMPLIANCE FORM NO.

990986

AIRCRAFT NO.: 368

MODEL: 1124A WESTWIND

AIRCRAFT REG.: N368ND

PAGE 1

91256 99-001 27 29	WORK DUE AT			
	DATE	HOURS	LANDINGS	CYCLES
		5028		

RECORD TIME WORK ACCOMPLISHED FOR EACH TASK. KEEP TOP COPY FOR YOUR RECORDS. RETURN CARBON COPY TO CSI FOR UPDATING.

CHECK CURRENT DUE LIST FOR DUE TIME CHANGES

WORK ACCOMPLISHED: DATE: MONTH 6 DAY 23 YEAR 9 AIRCRAFT HOURS: 5020.8 LANDINGS: 13654

TECHNICIAN SIGNATURE: [Signature] CERTIFICATE NUMBER: _____

INSPECTED BY: [Signature] KIND OF CERTIFICATE: _____

THE FOLLOWING WORK IS DUE AT THE TIME(S) NOTED ABOVE:

	TECHNICIAN	INSPECTOR	MAN-HOURS
			HRS. THS
990986 AD 90-10-04 INSPECT RIGHT HAND AILERON CONTROL ROD.....	<u>2715</u>	<u>[Signature]</u>	

REASON: TO DETECT CORROSION IN THE AILERON CONTROL ROD ASSEMBLY, ACCOMPLISH THE FOLLOWING:

COMPLIANCE: WITHIN 20 HOURS TIME-IN-SERVICE AFTER THE EFFECTIVE DATE OF THIS AD, AND THEREAFTER AT INTERVALS NOT TO EXCEED 150 HOURS TIME-IN-SERVICE, PERFORM A DETAILED VISUAL INSPECTION TO DETECT EVIDENCE OF CORROSION, SUCH AS PITS, AND/OR BLISTERS UNDER THE PAINT, ON THE LOWER EXTERIOR SURFACE OF THE AILERON TORQUE TRANSFER TUBES, IN ACCORDANCE WITH WESTWIND ASTRA SERVICE BULLETINS 1124-27-100, REVISION I.

REFER TO APPLICABLE AIRWORTHINESS DIRECTIVE FOR PROCEDURE.

OPERATOR: ED-WES, INC.

REPORT DATE 06/13/91

WORK COMPLIANCE FORM NO.

32.530

AIRCRAFT NO.: 368

MODEL: 1124A WESTWIND

AIRCRAFT REG.: N368MD

ISSUED 12-88 REV.

PAGE 1

91164

WORK DUE AT

* = APU HRS.

RECORD TIME WORK ACCOMPLISHED FOR EACH TASK. KEEP TOP COPY FOR YOUR RECORDS. RETURN CARBON COPY TO CSI FOR UPDATING.

32-065

DATE

HOURS

LANDINGS

CYCLES

29 29

4967

CHECK CURRENT DUE LIST FOR DUE TIME CHANGES

WORK ACCOMPLISHED: DATE: MONTH 6 DAY 19 YEAR 91 AIRCRAFT HOURS: 4878 LANDINGS: 3470

TECHNICIAN SIGNATURE: _____ CERTIFICATE NUMBER: _____

INSPECTED BY: *M. Jones* KIND OF CERTIFICATE: _____

THE FOLLOWING WORK IS DUE AT THE TIME(S) NOTED ABOVE: TECHNICIAN INSPECTOR MAN-HOURS
HRS. THS

32025 CHECK NOSE GEAR STRUT BODY...MM 5-20-01..... *MJE*

32025

CHECK NOSE GEAR STRUT BODY

1. CHECK INNER AND OUTER BODY TRUNNION AND CYLINDER LENGTH FORGING PARTING PLANE AND ROOT LUGS FOR GENERAL CONDITION, CRACKS, CORROSION, SECURITY OF ATTACHMENT AND LEAKAGE.
2. RECORD CHECK COMPLIED WITH IN SPACE PROVIDED ON PAGE 1.

OPERATOR: ED-WES, INC.

WORK COMPLIANCE FORM NO.

AIRCRAFT NO.: 368

MODEL: 1124A WESTWIND

AIRCRAFT REG.: N368MD

PAGE 1

92013

WORK DUE AT DATE	HOURS	* = APU HRS. LANDINGS	CYCLES
29 29			

RECORD TIME WORK ACCOMPLISHED FOR EACH TASK. KEEP TOP COPY FOR YOUR RECORDS. RETURN CARBON COPY TO CSI FOR UPDATING.

UNSCHEDULED

COMPONENT UPDATE:

WORK ACCOMPLISHED: DATE: MONTH 7 DAY 12 YEAR 91 ENGINE AIRCRAFT HOURS: 4635.6 LANDINGS: 3192

TECHNICIAN SIGNATURE: P/C/W CERTIFICATE NUMBER: GARRETT L.A.

INSPECTED BY: M Game KIND OF CERTIFICATE:

CODE: R725D11 PART NAME: DISC, STG 3 LP TURB L ENG

REASON REMOVED: (CHECK ONE) TIME A() FAIL B(X) WORN C() LOANER D() SCHED CONV E() MOD G() SERVICE K() ENG CHG L() TIRE CHG M() DAMAGED T()

PART REMOVED: PART NUMBER 3072544-2 SERIAL NUMBER: 0-18040-7673

PART INSTALLED: PART NUMBER 3072544-2 SERIAL NUMBER: 9-03229-4110

TIME SINCE NEW: HRS 0 LDGS MOS TIME SINCE OVERHAUL: HRS 0 LDGS MOS

WARRANTY TIME REMAINING: HRS LDGS MOS MAN-HOURS: HRS TENTHS PRICE: \$

REMARKS: Form No 71-010 / Code R725D11 WHICH THIS PAGE REFERS TO HAS PREVIOUSLY BEEN C/W.

SERVICE/INSPECTION UPDATE:

WORK ACCOMPLISHED: DATE: MONTH DAY YEAR AIRCRAFT HOURS: LANDINGS:

TECHNICIAN SIGNATURE: CERTIFICATE NUMBER:

INSPECTED BY: KIND OF CERTIFICATE:

CODE JOB DESCRIPTION TECHNICIAN INSPECTOR MAN-HOURS HRS. THS

REMARKS:

OPERATOR: ED-WES, INC.

AIRCRAFT NO.: 368

AIRCRAFT REG.: N368MD

MODEL: 1124A WESTWIND

ISSUED 07-83 REV.

PAGE 1

91119 00-000 29 29	WORK DUE AT			* = APU HRS.	RECORD TIME WORK ACCOMPLISHED FOR EACH TASK. KEEP TOP COPY FOR YOUR RECORDS. RETURN CARBON COPY TO CSI FOR UPDATING.
	DATE	HOURS	LANDINGS		

UNSCHEDULED

WORK ACCOMPLISHED: DATE: MONTH 1 DAY 15 YEAR 92 AIRCRAFT HOURS: 5012 LANDINGS: 3648

TECHNICIAN SIGNATURE: J.F. McRae CERTIFICATE NUMBER: _____

INSPECTED BY: _____ KIND OF CERTIFICATE: _____

TECHNICIAN	INSPECTOR	MAN-HOURS
<input checked="" type="checkbox"/>	<input type="checkbox"/>	HRS. THS

- 250156 INSPECT LIFE PRESERVER...NO REF.....
- 250161 INSPECT LIFE RAFT...NO REF.....
- 250162 INSPECT FIRST AID KIT...NO REF.....

NO TEXT AVAILABLE AT THIS TIME.

Life vest recertified by J.F. McRae

Aero craft inc. on 11/5/92

FAA repair station QQ 3R 79FL

See tag date 11/5/92 and

W/o 06300

ISS'D	7-88
REV'D	

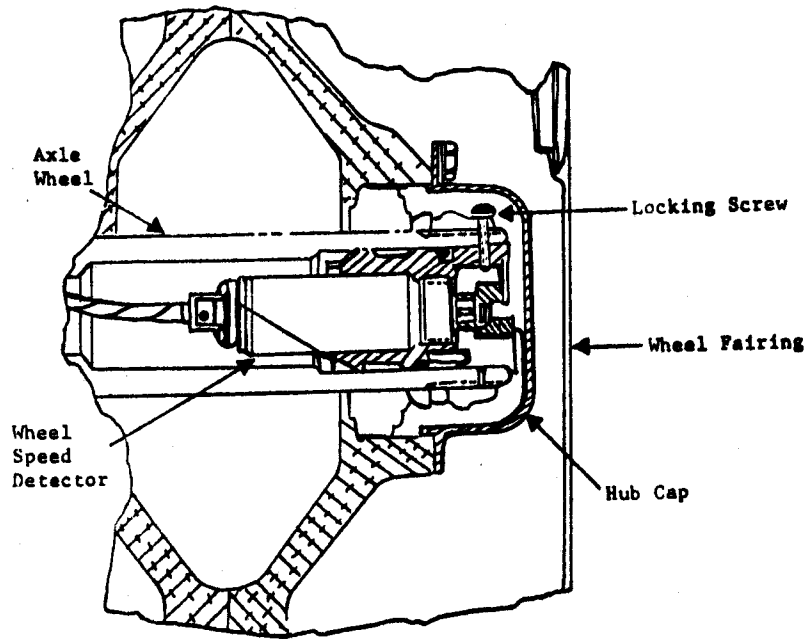

Anti-Skid Detector Installation

SERVICEABLE PARTS TAG

KaiserAir, Inc.

CRS # COZR942C

Oakland International Airport Oakland, CA 94614 415-569-9622

9/89

Part Number <i>5002F06-2</i>	Description <i>MLG WHL ASSY</i>			
Work Order Number <i>911300-201</i>	Serial Number/Quantity <i>MAR 80-550</i> <i>lea</i>			
Time Since (N)ew/(O)verhaul (<i>0</i>) <i>Q</i> /Hrs <i>Q</i> /Cyc	Authorized Signature/Date <i>C. Hoffhouse</i> <i>12-17-91</i>			
() Repair	() Modify	(<input checked="" type="checkbox"/>) Overhaul	() Tested	() NDT

This component has been repaired or overhauled and inspected in accordance with the current manufacturer's procedures and the federal aviation regulations and was found air-worthy with respect to the work performed and is approved for return to service. Pertinent details of work accomplished are on file at this station.

LESS HEAT SHIELD,

PN 249K83-3

SN 12042169

KA-25 YELLOW

KAISERAIR, INC.

HANGAR 7
OAKLAND INTERNATIONAL AIRPORT
OAKLAND, CA 94614

TEARDOWN/INSPECTION REPORT

KAISERAIR, INC.
P.O. BOX 2626/AIRPORT STATION
OAKLAND, CA 94614-2626

TELEPHONE: (415) 569-9622
TELEX: 497-3439 KATS UT
FAX: (415) 635-3173
CRS # COZR942C

PART NUMBER 5002806-2	SERIAL NUMBER MAR 80-550	DESCRIPTION MKS WHL ASSY	WORK ORDER NUMBER 911300	ITEM NUMBER 201
---------------------------------	------------------------------------	------------------------------------	------------------------------------	---------------------------

UNIT RECEIVED FOR: <input type="checkbox"/> MODIFICATION <input type="checkbox"/> REPAIR <input type="checkbox"/> INVESTIGATION <input type="checkbox"/> CERT. FOR REMAINDER OF LIFE <input type="checkbox"/> CUSTOMER OK TO MOD. <input type="checkbox"/> PRE-TEST <input type="checkbox"/> O/H & TESTED <input type="checkbox"/> CERT. TO ZERO HRS.	<input type="checkbox"/> TESTING ONLY <input checked="" type="checkbox"/> OVERHAUL <input checked="" type="checkbox"/> N. D. T. <input type="checkbox"/> WARRANTY <input type="checkbox"/> MODIFIED <input type="checkbox"/> REPAIR & TESTED <input type="checkbox"/> OTHER (Specify) _____	INITIAL INSPECTION: <input checked="" type="checkbox"/> NO EXTERNAL DEFECTS NOTED <input type="checkbox"/> UNIT LEAKING <input type="checkbox"/> INCOMPLETE/MISSING PARTS
--	--	---

UNIT STATUS: <input checked="" type="checkbox"/> NO DEFECTS NOTED <input type="checkbox"/> REPLACED ALL NECESSARY PARTS <input type="checkbox"/> UNIT CONTAMINATED <input type="checkbox"/> NO PARTS REQUIRED <input checked="" type="checkbox"/> RESEALED UNIT <input type="checkbox"/> UNIT SETTING OUT OF ADJUSTMENT <input type="checkbox"/> CANNOT CONFIRM <input type="checkbox"/> ASSY WORK BEYOND LIMITS <input type="checkbox"/> OTHER (Specify) _____	MODIFICATIONS ACCOMPLISHED MOD NUMBER DESCRIPTION NO MODS INCORPORATED
---	---

QTY	PART NUMBER	DESCRIPTION	QTY	PART NUMBER	DESCRIPTION	QTY	PART NUMBER	DESCRIPTION
1cc	5006678	PKK						
3cc	9524796	PKK						
1cc	RG-30	PKK						

WORK PROGRESSION DISASSEMBLED <u>JP</u> _____ CLEANED <u>JP</u> _____ INSPECTED/CHECKED <u>JP</u> _____ REPAIRED <u>JP</u> _____ ASSEMBLED <u>JP</u> _____ FINAL TEST <u>JP</u> _____	WORK ACCOMPLISHED OVERHAULED ABOVE WHEEL ASSY I.A.W. LATEST MFG SPECS ALL N.D.T. WORK C/W RE; BEAD SEAT AREAS EDDY CURRENT TESTED ALL OTHER AREAS D.P.I., TIE BOLTS M.P.I. REPAINT TO CUSTOMER COLOR AND FACTORY SPECS. ASSEMBLED w/ ORIGINAL TIRE (69 LOGS)
--	---

The above unit has been assembled and tested and is ready for return to service.

Tech JP Date 12-17-91

The above unit has been inspected and tested and is ok for return to service.

Insp _____ Date 12-17-91

OPERATOR: ED-WES, INC.

WORK COMPLIANCE FORM NO. 32.190

AIRCRAFT NO.: 368

MODEL: 11244 WESTWIND

AIRCRAFT REG.: N368MD

ISSUED 07-88 REV. 08-89

PAGE 1

91016	WORK DUE AT	* = APU HRS			RECORD TIME WORK ACCOMPLISHED FOR EACH TASK. KEEP TOP COPY FOR YOUR RECORDS. RETURN CARBON COPY TO CSI FOR UPDATING.
32-022	DATE	HOURS	LANDINGS	CYCLES	
29 29					UNSCHEDED

WORK ACCOMPLISHED: DATE: MONTH 2 DAY 13 YEAR 92 AIRCRAFT HOURS: 5041 LANDINGS: 3674

TECHNICIAN SIGNATURE: [Signature] CERTIFICATE NUMBER: 560767790

INSPECTED BY: [Signature] KIND OF CERTIFICATE: A+P

321171 PART NAME: RIGHT MAIN GEAR WHEEL MM 32-40-00
 REASON REMOVED: (CHECK ONE) TECHNICIAN: [Signature] INSP: [Signature]
 TIME A () FAIL B () WORN C () LOANER D () SCHED CONV E () MOD G () SERVICE K () ENG CHG L () TIRE CHG M () DAMAGED T ()

PART REMOVED: PART NUMBER 5002906-2 SERIAL NUMBER: JUN 89-470

PART INSTALLED: PART NUMBER 5002806-2 SERIAL NUMBER: MAR 80-550

TIME SINCE NEW: HRS _____ LDGS _____ MOS _____ TIME SINCE OVERHAUL: HRS 0 LDGS _____ MOS _____

WARRANTY TIME REMAINING: HRS _____ LDGS _____ MOS _____ MAN-HOURS: HRS _____ TENTHS _____ PRICE: \$ _____
SIGNOFF ANY WORK ACCOMPLISHED BELOW.

- 321176 INSPECT/LUBE RIGHT MAIN GEAR WHEEL BEARINGS...MM 32-40-00.....
- 321186 REPLACE RIGHT MAIN WHEEL BOLTS...NO REF.....
- R 321178 DYE PENETRANT RIGHT WHEEL AXLE...REFER TO WORK COMPLIANCE FORM 32.550
- R 322171 INSPECT/CLEAN RIGHT ANTI-SKID DETECTOR...REFER TO WORK COMPLIANCE FORM 32.410A
- R 321191 INSPECT RIGHT MAIN GEAR/WELL...REFER TO WORK COMPLIANCE FORM 32.020
- R 322174 OPERATIONAL CHECK ANTI-SKID LIGHTS...REFER TO WORK COMPLIANCE FORM 32.425

321181 PART NAME: RIGHT MAIN GEAR TIRE MM 32-40-00
 REASON REMOVED: (CHECK ONE) TECHNICIAN: [Signature] INSP: [Signature]
 TIME A () FAIL B () WORN C () LOANER D () SCHED CONV E () MOD G () SERVICE K () ENG CHG L () TIRE CHG M () DAMAGED T ()

PART REMOVED: PART NUMBER 249K83-3 SERIAL NUMBER: 00951068

PART INSTALLED: PART NUMBER 249K83-3 SERIAL NUMBER: 12042169

TIME SINCE NEW: HRS _____ LDGS _____ MOS _____ TIME SINCE OVERHAUL: HRS _____ LDGS _____ MOS _____

WARRANTY TIME REMAINING: HRS _____ LDGS _____ MOS _____ MAN-HOURS: HRS _____ TENTHS _____ PRICE: \$ _____

320671, 321171

NOTE: THE FOLLOWING ADDITIONAL WCF(S) ARE REQUIRED TO PERFORM THIS TASK 32.T01, 32.410.

ITEM 1 - MAIN LANDING GEAR WHEEL - REMOVAL AND INSTALLATION; INSPECT/LUBE WHEEL BEARINGS, REPLACE WHEEL BOLTS (REFER TO FIGURES 1 AND 2 ON CARD 32-5)
 EQUIPMENT/CONSUMABLES: TORQUE WRENCH 0 TO 400 INCH-POUNDS, GREASE MIL-G-91322, LOCKWIRE, NITROGEN SOURCE
 A REMOVAL (REFER TO FIGURES 1 AND 2)

NOTE: BE EXTREMELY CAREFUL WHEN REMOVING THE MAIN WHEEL FROM ITS AXLE. DO NOT ALLOW THE WHEEL TO HIT THE SPEED DETECTOR SHAFT. THIS COULD CAUSE MISALIGNMENT OF THE SHAFT AND EVENTUAL FAILURE OF THE SPEED DETECTOR. REMOVAL OF THE SPEED DETECTOR IS RECOMMENDED EACH TIME THE MAIN WHEEL ASSEMBLY IS REMOVED FOR ROUTINE OR NON-ROUTINE MAINTENANCE. INSPECT AXLE INTERIOR AND DETECTOR FOR MOISTURE AND/OR CORROSION AND CORRECT AS REQUIRED. REFER TO WORK COMPLIANCE FORM 32.410.

1. JACK AIRCRAFT. REFER TO WORK COMPLIANCE FORM 32.T01.

OPERATOR: ED-WES, INC.

REPORT DATE 09/16/91

WORK COMPLIANCE FORM NO.

32.425

AIRCRAFT NO.: 368

MODEL: 1124A WESTWIND

OPER01

AIRCRAFT REG.: N368MD

ISSUED 07-88 REV.

050150+ 150 HR INSPECTION

91259

WORK DUE AT		* = APU HRS	
DATE	HOURS	LANDINGS	CYCLES
	3028		

RECORD TIME WORK ACCOMPLISHED FOR EACH TASK. KEEP TOP COPY FOR YOUR RECORDS. RETURN CARBON COPY TO CSI FOR UPDATING.

32-033

29 29

CK CURRENT DUE LIST FOR DUE TIME CHGS

PAGE 1

WORK ACCOMPLISHED: DATE: MONTH 1 DAY 29 YEAR 91 AIRCRAFT HOURS: 5020.9 LANDINGS: 53654

TECHNICIAN SIGNATURE: _____ CERTIFICATE NUMBER: _____

INSPECTED BY: [Signature] KIND OF CERTIFICATE: _____

TECHNICIAN	INSPECTOR	MAN-HOURS
		HRS. THS
	<u>P.H.</u>	

322174 OPERATIONAL CHECK ANTI-SKID LIGHTS...MM 5-20-04.....

322174

OPERATIONAL CHECK ANTI-SKID LIGHTS

1. CHECK ANTI-SKID SYSTEM AS FOLLOWS:

- A. ANTI-SKID CONTROL SWITCH - OFF (BOTH ANTI-SKID INOP LIGHTS ON).
- B. ANTI-SKID CONTROL SWITCH - ON (BOTH ANTI-SKID INOP LIGHTS OUT).

2. RECORD OPERATIONAL CHECK COMPLIED WITH IN SPACE PROVIDED ON PAGE 1.

OPERATOR: ED-WES, INC.

REPORT DATE 09/16/91

WORK COMPLIANCE FORM NO.

32.440

AIRCRAFT NO.: 368

MODEL: 1124A WESTWIND

OPER01

AIRCRAFT REG.: N368MD

ISSUED 07-88 REV. 07-91

050150+ 130 HR INSPECTION

RECORD TIME WORK ACCOMPLISHED FOR EACH TASK. KEEP TOP COPY FOR YOUR RECORDS. RETURN CARBON COPY TO CSI FOR UPDATING.

91259

WORK DUE AT		* = APU HRS.	
DATE	HOURS	LANDINGS	CYCLES
32-057			
29 29	5028		

CK CURRENT DUE LIST FOR DUE TIME CHGS

PAGE 1

WORK ACCOMPLISHED: DATE: MONTH 1 DAY 22 YEAR 92 AIRCRAFT HOURS: 5028.8 LANDINGS: 3654

TECHNICIAN SIGNATURE: [Signature] CERTIFICATE NUMBER: _____

INSPECTED BY: [Signature] KIND OF CERTIFICATE: _____

TECHNICIAN	INSPECTOR	MAN-HOURS
		HRS. THS

32206 OPERATIONAL CHECK EMERGENCY GEAR EXTENSION CABLE...MM 32-00-00..... [Signature]

32206

OPERATIONAL CHECK EMERGENCY GEAR EXTENSION CABLE

1. REMOVE CLEVIS PINLOCATED IN ARM OF ACTUATING VALVE AND OPERATE EMERGENCY GEAR DOWN HANDLE ON PILOT'S PEDESTAL SEVERAL TIMES. CHECK FOR FREEDOM OF MOVEMENT.
- R 2. REINSTALL AND SAFETY CLEVIS PIN REMOVED IN STEP 1.
3. RECORD CHECK COMPLIED WITH IN SPACE PROVIDED ON PAGE 1.

OPERATOR: ED-WES, INC.

REPORT DATE 09/16/91

WORK COMPLIANCE FORM NO.

34.060

AIRCRAFT NO.: 368

MODEL: 1124A WESTWIND

CARD NO: 34-3

OPER01

AIRCRAFT REG.: N368MD

ISSUED 07-88 REV.

050150+ 150 HR INSPECTION

RECORD TIME WORK ACCOMPLISHED FOR EACH TASK. KEEP TOP COPY FOR YOUR RECORDS. RETURN CARBON COPY TO CSI FOR UPDATING.

Table with columns: WORK DUE AT, DATE, HOURS, LANDINGS, CYCLES, CK CURRENT DUE LIST FOR DUE TIME CHGS, PAGE 1

WORK ACCOMPLISHED: DATE: MONTH 1 DAY 22 YEAR 92 AIRCRAFT HOURS: 5020.8 LANDINGS: 31654

TECHNICIAN SIGNATURE: [Signature] CERTIFICATE NUMBER: [Blank]

INSPECTED BY: [Signature] KIND OF CERTIFICATE: [Blank]

Table with columns: TECHNICIAN, INSPECTOR, MAN-HOURS

340121 DRAIN PITOT/STATIC SYSTEM...MM 34-10-01... 340121 DRAIN PITOT/STATIC SYSTEM (REFER TO ILLUSTRATION ON CARD 34-3)

- NOTE: 1. FOR 1124 MODELS, USE STEP 1. 2. FOR 1124A MODELS, USE STEP 2.

1. DRAIN PITOT/STATIC SYSTEM (1124 MODELS) AS FOLLOWS: A. FOUR STATIC-LINE DRAIN VALVES ARE LOCATED AT FUSELAGE STATION 80.50 AND ARE ACCESSIBLE FROM OUTSIDE THE FUSELAGE...

NOTE: AIRCRAFT S/N 240 AND SUBSEQUENT HAVE STATIC DRAIN AT ADC 80 AND/OR TAS COMPUTER.

B. TWO PITOT LINE DRAIN TRAPS ARE LOCATED FORWARD OF THE PRESSURE BULKHEAD AND INBOARD OF THE PITOT HEADS INSIDE THE NOSE COMPARTMENT AT FUSELAGE STATION 10.14. THEY ARE SITUATED ONE ON EACH SIDE OF THE AIRCRAFT...

2. DRAIN PITOT/STATIC SYSTEM (1124A MODELS) AS FOLLOWS: A. FOUR STATIC-LINE DRAIN VALVES ARE LOCATED AT FUSELAGE STATION 83.75 AND ARE ACCESSIBLE FROM OUTSIDE THE FUSELAGE... B. TWO PITOT PROBE LINE DRAIN TRAPS ARE LOCATED INSIDE THE NOSE COMPARTMENT AT FUSELAGE STATION 10.14... C. AFTER DRAINING, IF ANY OF THE PITOT/STATIC INSTRUMENTS ARE ERRATIC... D. CHECK THAT THE LEFT STATIC HEATER AND PITOT HEATERS ARE OPERATIVE.

CAUTION: BEFORE PLACING PITOT/STATIC ANTI-ICE SWITCH IN THE 'ON' POSITION MAKE SURE THAT THE PITOT TUBE COVERS ARE REMOVED. PLACE THE PITOT/STATIC ANTI-ICE SWITCH TO 'ON' POSITION ONLY MOMENTARILY UNTIL PITOT AND STATIC HEAT CAN BE PHYSICALLY DETECTED BY TOUCH. DO NOT OPERATE HEATERS FOR MORE THAN TWO MINUTES. DAMAGE TO HEATERS MAY RESULT.

3. RECORD DRAINING COMPLIED WITH IN SPACE PROVIDED ON PAGE 1.

ISS'D	7-88
REV'D	

PITOT AIR DATA AND
COMPUTER DRAIN TRAP



NOSE COMPARTEMENT
(STA 83, 174 and 250
on 1124A ONLY) (ALSO
STA 250 for 590 A3 K1 AND
J1 AIR DATA COMPUTERS
1124 S/N 240 and SUBS)

TUBING DRAIN VALVES

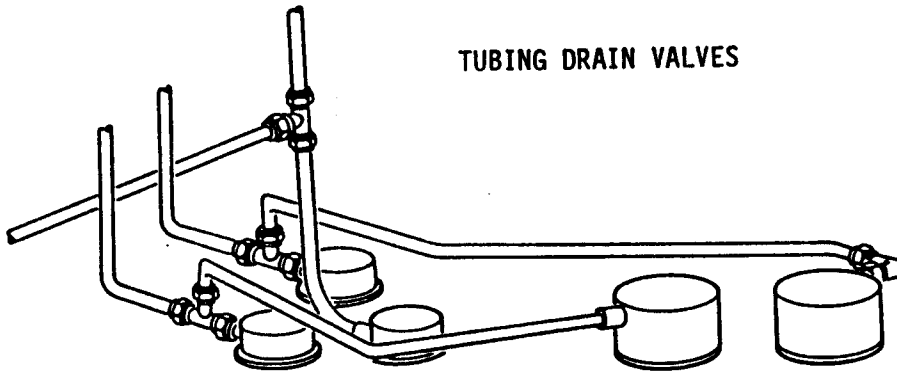

Typical Drain Valve

1124

34-3

OPERATOR: ED-WES, INC.
 AIRCRAFT NO.: 368
 AIRCRAFT REG.: N368MD

REPORT DATE 09/16/91
 MODEL: 1124A WESTWIND

WORK COMPLIANCE FORM NO. 52.010A
 CARD NO: 52- 1 OPERO1

ISSUED 07-88 REV. 050150+ 130 HR INSPECTION

RECORD TIME WORK ACCOMPLISHED FOR EACH TASK. KEEP TOP COPY FOR YOUR RECORDS. RETURN CARBON COPY TO CSI FOR UPDATING.

91259
 52-002
 29 29

WORK DUE AT		* = APU HRS.	
DATE	HOURS	LANDINGS	CYCLES
	5028		

CK CURRENT DUE LIST FOR DUE TIME CHGS PAGE 1

WORK ACCOMPLISHED: DATE: MONTH 1 DAY 22 YEAR 92 AIRCRAFT HOURS: 5020.8 LANDINGS: 3654

TECHNICIAN SIGNATURE: [Signature] CERTIFICATE NUMBER: _____
 INSPECTED BY: [Signature] KIND OF CERTIFICATE: _____

TECHNICIAN INSPECTOR MAN-HOURS
 HRS. THS

[Signature]

520106 INSPECT/LUBRICATE CABIN ENTRANCE DOOR...MM 52-10-00.....

520106

INSPECT/LUBRICATE CABIN ENTRANCE DOOR (REFER TO FIGURE 2 ON CARD 52-1)

CONSUMABLES: SILICONE LUBRICANT, LUBRICATING OIL MIL-L-7820A

1. INSPECT DOOR, STEP, TRACKS, UPPER AND LOWER FLAPPERS, SEAL AND ALL ATTACHMENTS FOR SECURITY, CLEANLINESS AND GENERAL CONDITION.
2. CHECK THAT SPRING-LOADED LATCH AND LATCH BAYONETS ARE FULLY EXTENDED WHEN DOOR IS IN CLOSED POSITION.
3. CHECK THAT SPRING-LOADED LATCH AND LATCH BAYONETS ARE FULLY RETRACTED WHEN DOOR IS IN OPEN POSITION.
4. WITH DOOR CLOSED AND LATCHES ENGAGED, PULL OUTSIDE HANDLE OUT OF RECESS AND ROTATE COUNTERCLOCKWISE TO DISENGAGE LATCHES. ENSURE THAT SUFFICIENT FORCE IS REQUIRED TO RELEASE LATCHES.
5. ROTATE OUTSIDE HANDLE CLOCKWISE TO ENGAGE LATCHES. ENSURE THAT SUFFICIENT FORCE IS REQUIRED TO ENGAGE LATCHES.
6. REPEAT STEPS 4 AND 5 TO CHECK INSIDE HANDLES.
7. CLEAN AND LUBRICATE DOOR SEAL USING SILICONE LUBRICANT AS PER FIGURE 2.

NOTE: A VERY LIGHT COAT SHOULD BE APPLIED; TOO MUCH LUBRICANTION WILL COLLECT DIRT AND CAUSE LEAKAGE AT DOOR SEAL.

8. LUBRICATE DOOR WITH LUBRICATING OIL MIL-L-7870A AS PER FIGURE 2.
9. RECORD INSPECTION/LUBRICATION COMPLIED WITH IN SPACE PROVIDED ON PAGE 1.

ISS'D	7-88
REV'D	

INSTALL BEAD OF PR 1422 SEALANT BETWEEN DOOR SKIN AND FLAPPER SEAL IN THIS AREA

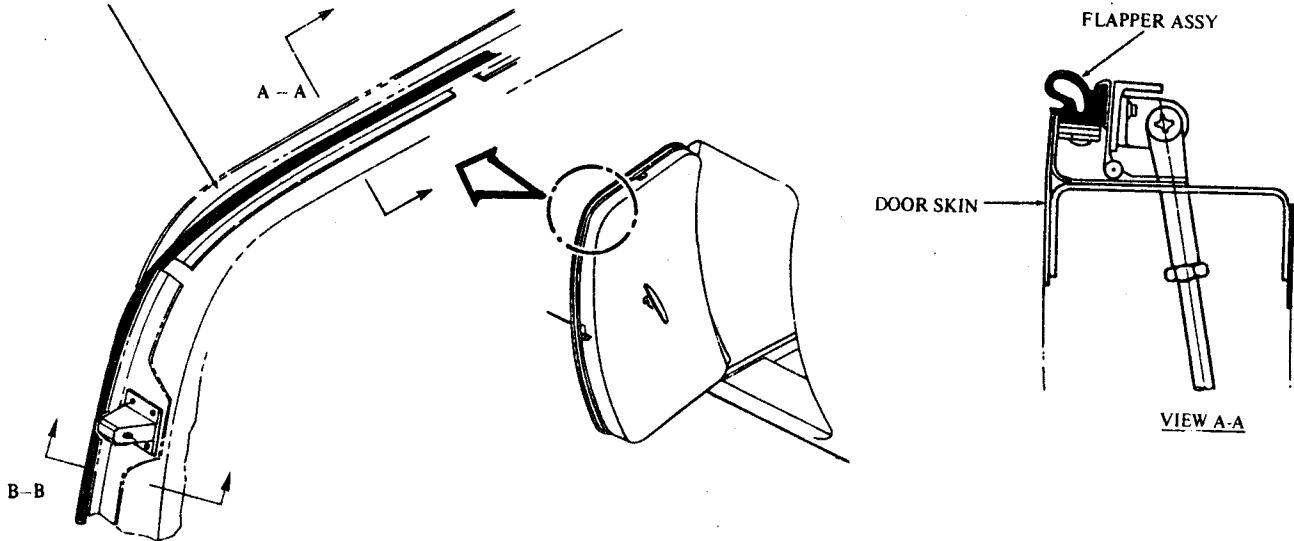

IF GAP EXISTS IN THIS AREA
FILL WITH RTV-102 SILICONE
COMPOUND

Entrance Door Seal Installation
Figure 1

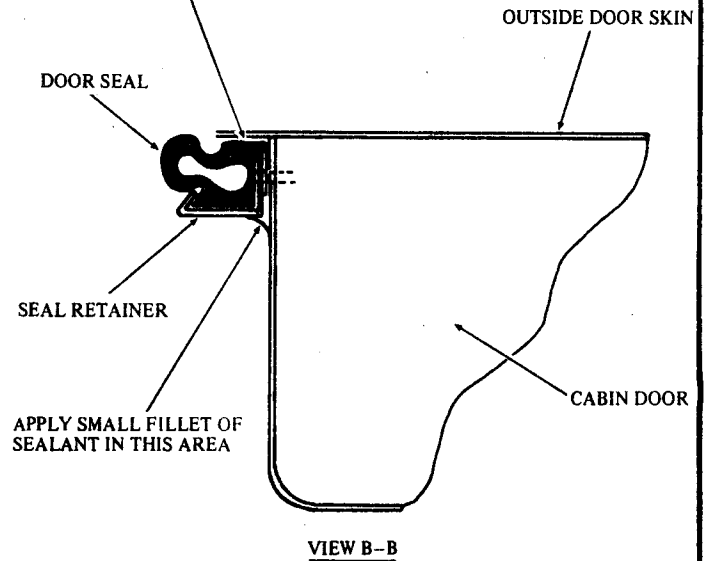

ISS'D	7-88
REV'D	

TYPE OF LUBRICANTS		
SYMBOL	MILITARY SPECIFICATION	TYPE OF LUBRICANT
OGP	MIL-L-7870A	Oil Low Temperature Range
		Silicone Base Lubricant

APPLICATION SYMBOLS
Oil Can

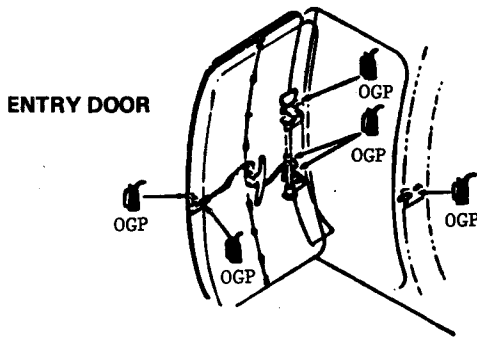

NOTE: Lubricate door seal with silicone base lubricant (as req'd).

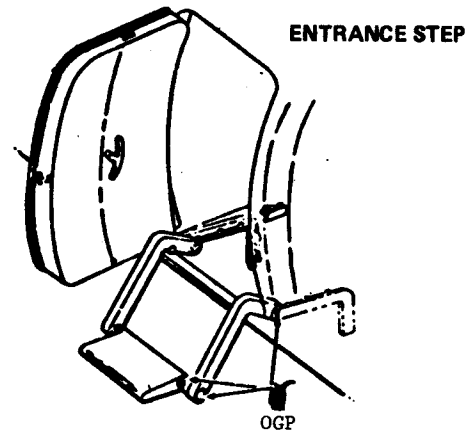

Entry Door/Step Lubrication

Figure 2

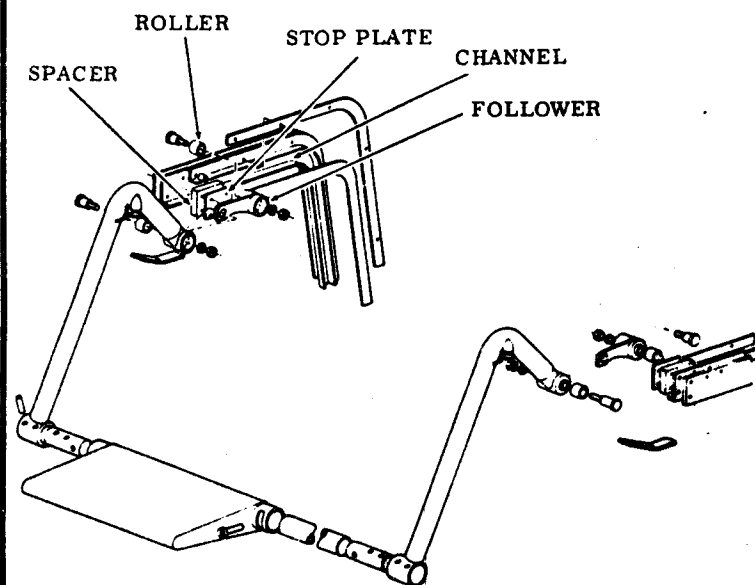

Entrance Step

Figure 3

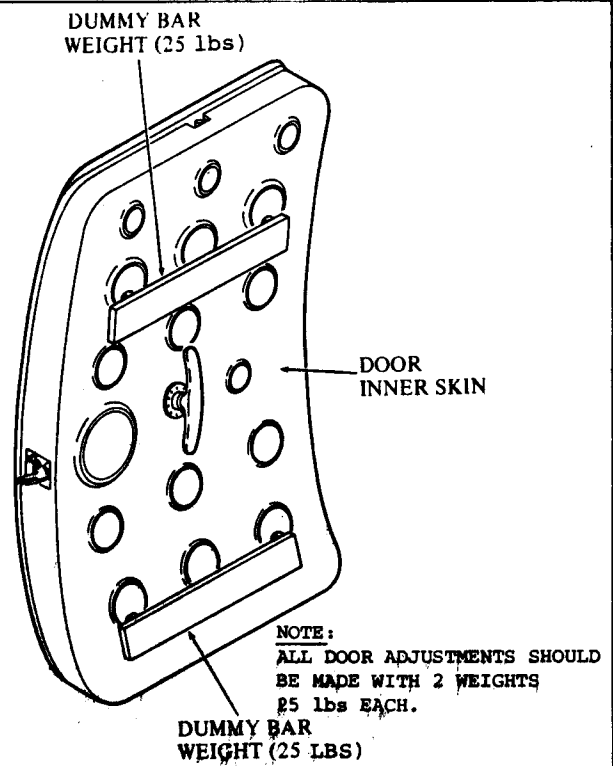

Main Entry Door -
Dummy Bar Installation

Figure 4

ISS'D	7-88
REV'D	

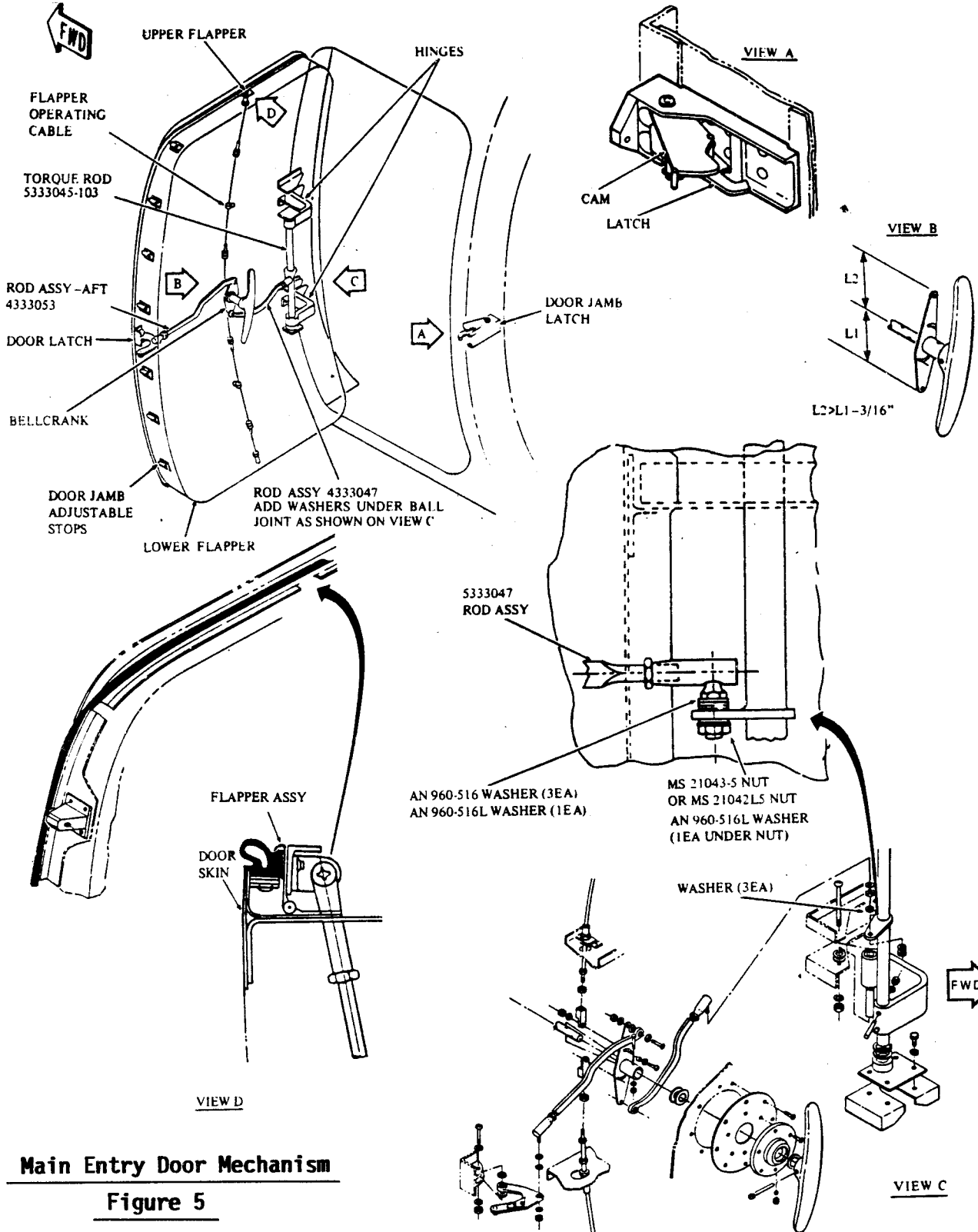

Main Entry Door Mechanism
Figure 5

OPERATOR: ED-WES, INC.

REPORT DATE 09/16/91

WORK COMPLIANCE FORM NO.

52.010B

AIRCRAFT NO.: 368

MODEL: 1124A WESTWIND

OPER01

AIRCRAFT REG.: N368MD

ISSUED 07-88 REV.

030150+ 130 HR INSPECTION

RECORD TIME WORK ACCOMPLISHED FOR EACH TASK. KEEP TOP COPY FOR YOUR RECORDS. RETURN CARBON COPY TO CSI FOR UPDATING.

91259

WORK DUE AT

* = APU HRS.

52-003

DATE

HOURS

LANDINGS

CYCLES

29 29

5028

CK CURRENT DUE LIST FOR DUE TIME CHGS

PAGE 1

WORK ACCOMPLISHED: DATE: MONTH 1 DAY 22 YEAR 92 AIRCRAFT HOURS: 5020.8 LANDINGS: 3654

TECHNICIAN SIGNATURE: [Signature] CERTIFICATE NUMBER: _____

INSPECTED BY: [Signature] KIND OF CERTIFICATE: _____

TECHNICIAN	INSPECTOR	MAN-HOURS
		HR5.THS

520116 OPERATIONAL CHECK CABIN ENTRANCE DOOR...MM 52-10-00..... [Signature] _____

520116

OPERATIONAL CHECK CABIN ENTRANCE DOOR

1. PULL OUTSIDE HANDLE OUT OF RECESS AND ROTATE COUNTERCLOCKWISE TO DISENGAGE LATCHES.
2. ENSURE THAT SUFFICIENT FORCE IS REQUIRED TO RELEASE LATCHES.
3. OPEN DOOR AND CHECK FOR SMOOTH OPERATION.
4. CHECK THAT SPRING-LOADED LATCH AND LATCH BAYONETS ARE FULLY RETRACTED WHEN DOOR IS IN OPEN POSITION.
5. CLOSE DOOR AND CHECK THAT SPRING-LOADED LATCH AND LATCH BAYONETS ARE EXTENDED WHEN DOOR IS CLOSED.
6. CHECK INSIDE DOOR HANDLE FOR SMOOTH OPERATION.
7. RECORD OPERATIONAL CHECK COMPLIED WITH IN SPACE PROVIDED ON PAGE 1.

OPERATOR: ED-WES, INC.
 AIRCRAFT NO.: 368
 AIRCRAFT REG.: N368MD

REPORT DATE 09/16/91
 MODEL: 1124A WESTWIND
 ISSUED 07-88 REV. 07-91

WORK COMPLIANCE FORM NO. 53.0201
 OPER01

050150+ 150 HR INSPECTION

91259
 53-002
 29 29

WORK DUE AT		* = APU HRS	
DATE	HOURS	LANDINGS	CYCLES
	5028		

RECORD TIME WORK ACCOMPLISHED FOR EACH TASK. KEEP TOP COPY FOR YOUR RECORDS. RETURN CARBON COPY TO CSI FOR UPDATING.

CK CURRENT DUE LIST FOR DUE TIME CHGS PAGE 1

WORK ACCOMPLISHED: DATE: MONTH 1 DAY 22 YEAR 92 AIRCRAFT HOURS: 5020.8 LANDINGS: 3654

TECHNICIAN SIGNATURE: Douglas CERTIFICATE NUMBER: _____

INSPECTED BY: Goswami KIND OF CERTIFICATE: _____

	TECHNICIAN	INSPECTOR	MAN-HOURS HRS. THS
530116 INSPECT NOSE COMPARTMENT (A).....	<u>AD</u>	<u>T.O.D</u>	

530116 INSPECT NOSE COMPARTMENT (A)

R TEXT FROM MM 5-20-01, 5-20-05

1. INSPECT PITOT LINES FOR CHAFING AND DAMAGE.
2. INSPECT STRUCTURE FOR CONDITION AND SECURITY.
3. INSPECT AC INVERTERS, COOLING FAN AND ELECTRICAL CONNECTIONS FOR SECURITY, CLEANLINESS AND GENERAL CONDITION.
4. CHECK BATTERIES FOR ANY EVIDENCE OF CORROSION OR PHYSICAL DAMAGE. CHECK VENT LINES FOR OBSTRUCTION AND SECURITY OF INSTALLATION.
5. FOR AIRCRAFT EQUIPPED WITH COLLINS WXR 300 WEATHER RADAR, CHECK THE CRYSTAL DESICCANT BOTTLE INSTALLED IN THE NOSE COMPARTMENT AS FOLLOWS:
 - A. CHECK DESICCANT BOTTLE CRYSTAL COLOR AGAINST COLOR COMPARISON CHART AFFIXED TO BOTTLE.
 - B. SHOULD CRYSTAL COLOR INDICATE NEED FOR REPLACEMENT REPLACE WITH A DESICCANT REFILL.
 - C. STEPS A. AND B. COMPLIED WITH.
6. CHECK BATTERY QUICK DISCONNECTS FOR CORROSION AND GENERAL CONDITION.
7. RECORD INSPECTION COMPLIED WITH IN SPACE PROVIDED ON PAGE 1.

MECH	INSP
<u>AD</u>	
<u>D</u>	
<u>N/A</u>	
<u>D</u>	
<u>N/A</u>	

OPERATOR: ED-WES, INC.
 AIRCRAFT NO.: 368
 AIRCRAFT REG.: N368MD

REPORT DATE 09/16/91
 MODEL: 1124A WESTWIND
 ISSUED 07-88 REV. 07-91

WORK COMPLIANCE FORM NO. 53.0401
 OPERO1

91259
 53-007
 29 29

WORK DUE AT	* = APU HRS		
DATE	HOURS	LANDINGS	CYCLES
	5028		

050150+ 150 HR INSPECTION
 RECORD TIME WORK ACCOMPLISHED FOR EACH TASK. KEEP TOP COPY FOR YOUR RECORDS. RETURN CARBON COPY TO CSI FOR UPDATING.

CK CURRENT DUE LIST FOR DUE TIME CHGS PAGE 1

WORK ACCOMPLISHED: DATE: MONTH 01 DAY 22 YEAR 92 AIRCRAFT HOURS: 5020.9 LANDINGS: 31054

TECHNICIAN SIGNATURE: Pat Hoffart CERTIFICATE NUMBER: _____

INSPECTED BY: J. O'Donnell KIND OF CERTIFICATE: _____

TECHNICIAN	INSPECTOR	MAN-HOURS
		HRS. THS

530146 INSPECT CABIN (150 HOUR)..... P.H. T.O.D

530146
 INSPECT CABIN (150 HOUR)

R TEXT FROM MM 5-20-02

1. INSPECT PASSENGER COMPARTMENT FOR CLEANLINESS, SECURITY AND GENERAL CONDITION.
2. REMOVE THE COVER FROM THE AFT RELAY PANEL, AND CHECK INSIDE FOR CLEANLINESS, SAFETY, CONDITION AND EVIDENCE OF OVERHEATING OF ELECTRICAL PARTS.
3. INSPECT EMERGENCY LIGHT FOR OPERATION SECURITY, CLEANLINESS, AND CONNECTIONS. CHECK BATTERY CHARGE. (REFER TO MM 12-10-06)

MECH	INSP
<u>P.H.</u>	<u>P.H.</u>
<u>P.H.</u>	<u>P.H.</u>
<u>P.H.</u>	<u>P.H.</u>

NOTE: WHENEVER THE EMERGENCY LIGHTS HAVE BEEN OPERATED FROM THE EMERGENCY BATTERY FOR MORE THAN ONE HOUR, CHECK BATTERY CHARGE.

4. INSPECT REFRESHMENT BAR, ICE CHEST, GALLEY COAT CLOSET, CABINETS, TABLES, ETC., FOR EASE OF OPERATION, LOCK, GENERAL CONDITION AND SECURITY.
5. INSPECT SEATS AND SEAT BELTS FOR SECURITY AND GENERAL CONDITION.
6. CHECK CABIN OXYGEN SYSTEM FOR GENERAL CONDITION.
7. CHECK READING LIGHT FOR OPERATION AND GENERAL CONDITION.
8. CHECK VENTILATING AIR CONSOLE FOR CLEANLINESS AND GENERAL CONDITION.
- R 9. INSPECT WINDOWS FOR DELAMINATION, SCRATCHES AND CRACKS.
10. CHECK INTERIOR LIGHTS FOR OPERATION, CLEANLINESS AND GENERAL CONDITION.
11. CHECK EMERGENCY EXIT FOR SECURITY AND GENERAL CONDITION. CHECK RELEASE MECHANISM (PULL RELEASE HANDLE, BUT NOT NECESSARY TO REMOVE EXIT FROM AIRCRAFT).
12. CHECK CERTIFICATES.
13. INSPECT AVIONICS COMPONENTS FOR SECURITY, CLEANLINESS AND SECURE CONNECTIONS.
14. INSPECT LAVATORY AND BAGGAGE COMPARTMENT FOR SECURITY AND GENERAL CONDITION.
15. INSPECT LAVATORY DOOR FOR CONDITION AND OPERATION.
16. RECORD INSPECTION COMPLIED WITH IN SPACE PROVIDED ON PAGE 1.

<u>P.H.</u>	<u>P.H.</u>
<u>P.H.</u>	<u>P.H.</u>
<u>P.H.</u>	<u>P.H.</u>
<u>P.H.</u>	<u>P.H.</u>
<u>P.H.</u>	<u>P.H.</u>
<u>P.H.</u>	<u>P.H.</u>
<u>P.H.</u>	<u>P.H.</u>
<u>P.H.</u>	<u>P.H.</u>

OPERATOR: ED-WES, INC.
 AIRCRAFT NO.: 368
 AIRCRAFT REG.: N368MD

REPORT DATE 09/16/91
 MODEL: 1124A WESTWIND
 ISSUED 07-88 REV. 07-91

WORK COMPLIANCE FORM NO. 53.0301
 OPER01

91259	WORK DUE AT	* = APU HRS			030130+ 150 HR INSPECTION
53-010	DATE	HOURS	LANDINGS	CYCLES	RECORD TIME WORK ACCOMPLISHED FOR EACH TASK. KEEP TOP COPY FOR YOUR RECORDS. RETURN CARBON COPY TO CSI FOR UPDATING.
29 29		5028			CK CURRENT DUE LIST FOR DUE TIME CHGS

WORK ACCOMPLISHED: DATE: MONTH Jan DAY 21 YEAR 92 AIRCRAFT HOURS: 5020.8 LANDINGS: 31654

TECHNICIAN SIGNATURE: Martin Coolidge CERTIFICATE NUMBER: _____

INSPECTED BY: _____ KIND OF CERTIFICATE: _____

	TECHNICIAN	INSPECTOR	MAN-HOURS
			HRS. THS
530161 INSPECT REAR COMPARTMENT (A).....	<u>MMC</u>	<u>P.O.D.</u>	
530161			

R NOTE: THE FOLLOWING ADDITIONAL WCF(S) MAY BE REQUIRED TO PERFORM THIS TASK 29.030C.

INSPECT REAR COMPARTMENT (A)

R TEXT FROM MM 5-20-05

1. INSPECT FUSELAGE FUEL TANK AREA FOR GENERAL CONDITION AND LEAKAGE.
2. CHECK FUEL SUPPLY LINE FOR CONDITION.
3. INSPECT PRESSURE REFUELING POINT AREA AND FUEL BOOST PUMP AREA, FOR GENERAL CONDITION.
4. INSPECT FUEL SHUTOFF VALVES - CYCLE OFF AND ON, FOR GENERAL CONDITION AND LEAKAGE.
5. INSPECT AC AND DC ELECTRICAL COMPONENTS FOR SECURITY IN MOUNTS AND CONDITION.
6. INSPECT ELECTRICAL WIRE BUNDLES FOR DAMAGE AND SECURITY.
7. REMOVE THE COVERS FROM THE LEFT-HAND AND RIGHT-HAND DC CONTACTOR BOXES AND FLAP CONTACTOR BOX AND CHECK INSIDE FOR CLEANLINESS, SAFETY, CONDITION AND EVIDENCE OF OVERHEATING OF ELECTRICAL PARTS.
8. INSPECT ANTI-SKID CONTROL VALVE FOR LEAKAGE AND ELECTRICAL CONNECTIONS FOR CONDITION AND SECURITY OF ATTACHMENT.
9. CHECK HYDRAULIC SYSTEM COMPONENTS, FLUID CARRYING LINES AND FITTINGS FOR DAMAGE, CHAFING, LEAKAGE AND GENERAL CONDITION.

MECH INSP
MMC
MMC
MMC
MMC
MMC
MMC
MMC
MMC

NOTE: CHECK FOR CLEARANCE BETWEEN FLUID LINES, FLAP FLEX DRIVE CABLES AND AILERON TORQUE TUBES WHILE FLAPS AND AILERONS ARE MOVED THROUGH FULL TRAVEL.

10. CHECK LIFT DUMPER AND SPEED BRAKE SELECTOR VALVES FOR LEAKAGE AND CONDITION AND ELECTRICAL CONNECTIONS FOR SECURITY.
11. INSPECT HYDRAULIC POWER PANEL FOR LEAKAGE AND CONDITION.
12. CHECK HYDRAULIC HIGH PRESSURE FILTERS. CHECK RED POP-OUT BUTTON. IF BUTTON IS OUT (EXTENDED), THE FILTER IS CLOGGED; FILTER ELEMENT MUST BE REPLACED AND APPLICABLE PUMP CHECKED. FOR CAMP OPERATORS, REFER TO WORK COMPLIANCE FORM 29.030C. FOR SCAMP OPERATORS, REFER TO MAINTENANCE MANUAL.
13. CHECK HYDRAULIC EMERGENCY BRAKE SYSTEM ACCUMULATOR DRY NITROGEN CHARGE. REFER TO TABLE BELOW.

MMC
MMC
MMC
MMC

-20 DEGREES TO	+30 DEGREES F	170 + OR -5 PSI
+30 DEGREES TO	+80 DEGREES F	180 + OR -5 PSI
+80 DEGREES TO	+130 DEGREES F	190 + OR -5 PSI

TEXT FROM MM 5-20-05

14. CHECK THRUST REVERSER ACCUMULATOR AND CYLINDER DRY NITROGEN CHARGE. REFER TO TABLE BELOW.

MMC

-20 DEGREES TO	+30 DEGREES F	730 + OR -40 PSI
+30 DEGREES TO	+80 DEGREES F	825 + OR -40 PSI
+80 DEGREES TO	+130 DEGREES F	900 + OR -40 PSI

TEXT FROM MM 5-20-05

15. INSPECT HOSES, LINES AND ELECTRICAL BUNDLES ENTERING FUSELAGE FROM ENGINE NACELLES FOR DAMAGE, CHAFING, LEAKS AND SECURITY.
16. INSPECT PNEUMATIC DE-ICING EQUIPMENT AND ELECTRICAL CONNECTION FOR SECURITY AND CONDITION.

MMC
MMC

OPERATOR: ED-WES, INC.

REPORT DATE 09/16/91

WORK COMPLIANCE FORM NO.

53.0501

AIRCRAFT NO.: 368

MODEL: 1124A WESTWIND (CONTINUED)

OPER01

AIRCRAFT REG.: N368MD

ISSUED 07-88 REV. 07-91

050150+ 150 HR INSPECTION

91259

WORK DUE AT		* = APU HRS.	
DATE	HOURS	LANDINGS	CYCLES
	5028		

RECORD TIME WORK ACCOMPLISHED FOR EACH TASK. KEEP TOP COPY FOR YOUR RECORDS. RETURN CARBON COPY TO CSI FOR UPDATING.

53-010

29 29

CK CURRENT DUE LIST FOR DUE TIME CHGS

PAGE 2

17. INSPECT ELECTRICAL BUNDLES AND TERMINAL STRIPS FOR DAMAGE, SECURITY AND LOOSE CONNECTIONS.
18. INSPECT AIR EJECTOR FOR OBSTRUCTIONS AND CONDITION.
19. INSPECT FLAP PRIME MOVER AND FLEX SHAFTS FOR GENERAL CONDITION AND SECURITY.
20. INSPECT AUXILIARY TANK AREA FOR GENERAL CONDITION AND SECURITY. *Tank not installed*
21. RECORD INSPECTION COMPLIED WITH IN SPACE PROVIDED ON PAGE 1.

IMC

IMC

IMC

IMC

OPERATOR: ED-WES, INC.
 AIRCRAFT NO.: 368
 AIRCRAFT REG.: N368MD

REPORT DATE 09/16/91
 MODEL: 1124A WESTWIND
 ISSUED 07-88 REV. 07-91

WORK COMPLIANCE FORM NO. 54.0101
 CARD NO: 54- 1 OPER01

91259
 54-001
 29 29

WORK DUE AT DATE	HOURS	LANDINGS	CYCLES
	5028		

* = APU HRS
 RECORD TIME WORK ACCOMPLISHED FOR EACH TASK. KEEP TOP COPY FOR YOUR RECORDS. RETURN CARBON COPY TO CSI FOR UPDATING.

050150+ 150 HR INSPECTION

CK CURRENT DUE LIST FOR DUE TIME CHGS PAGE 1

WORK ACCOMPLISHED: DATE: MONTH 1 DAY 23 YEAR 92 AIRCRAFT HOURS: 5020.8 LANDINGS: 3654

TECHNICIAN SIGNATURE: E.L.B. CERTIFICATE NUMBER: _____
 INSPECTED BY: [Signature] KIND OF CERTIFICATE: _____

	TECHNICIAN	INSPECTOR	MAN-HOURS HRS. THS
340101 INSPECT LEFT ENGINE NACELLE/PYLON (A).....	<u>275</u>		
340121 INSPECT RIGHT ENGINE NACELLE/PYLON (A).....	<u>[Signature]</u>		

 340101, 340121
 INSPECT ENGINE NACELLE/PYLON (A) (FOR CAMP OPERATORS, REFER TO ILLUSTRATION ON CARD 54-1. FOR SCAMP OPERATORS, REFER TO MAINTENANCE MANUAL) MECH INSP
 R TEXT FROM MM 5-20-08

- NOTE: 1. DEPLOY THRUST REVERSER AND INSTALL GROUND DEPLOY LOCKS.
 2. REMOVE STANG COVERS AND ACCESS COVER (THROTTLE RETARDER FEEDBACK CONTROL).

- INSPECT THRUST REVERSER MECHANICAL SYSTEM INCLUDING THROTTLE RETARDER FEEDBACK CONTROL AND ACTUATOR, LINKAGE FOR CHAFING, DISTORTION, SECURITY AND EVIDENCE OF WORN BUSHINGS.
- INSPECT THRUST REVERSER FOR GENERAL CONDITION, CRACKS, CLEANLINESS, FOREIGN OBJECT DAMAGE, FLUID ACCUMULATION AND LOOSE OR WORKING FASTENERS.
- INSPECT THRUST REVERSER ACTUATOR MOUNTING AND STOP BOLTS FOR SECURITY AND SAFETYWIRE.
- REINSTALL ACCESS COVER AND STANG COVERS. REMOVE GROUND DEPLOY LOCKS AND RESTORE TO NORMAL POSITION.
- RECORD INSPECTION COMPLIED WITH IN SPACE PROVIDED ON PAGE 1.

E.L.B.
[Signature]
[Signature]

ISS'D	7-88
REV'D	

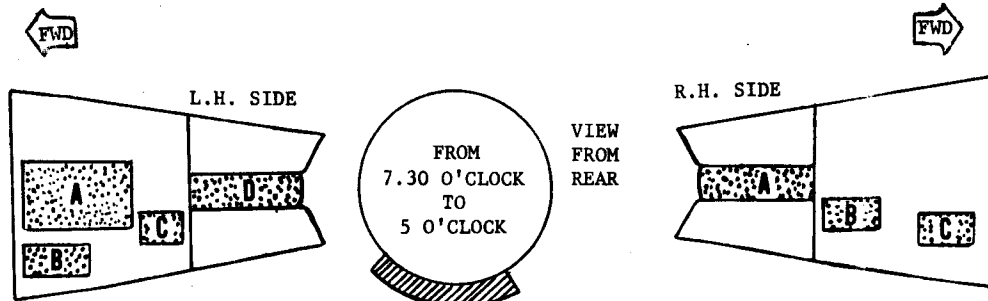

- A - AFT MOUNT, AFT FIRE EXT; THREE ELECT CONN. H.P. AIR, FIRE DETECTOR
- B - IGNITER PLUGS
- C - T/R ELECT. HARNESS
- D - T/R HYD. ACTUATOR

RIGHT-HAND ENGINE

- A - T/R, TWO SWITCHES SOLENOID LOCK
- B - THROTTLE RETARDER BOX
- C - THROTTLE RETARDEF LINKAGE

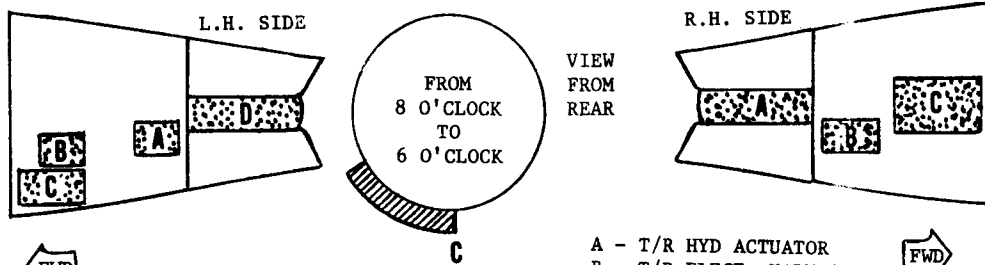

- A - THROTTLE RETARDER BOX
- B - THROTTLE RETARDER LINKAGE
- C - IGNITER PLUGS
- D - T/R, TWO SWITCHES SOLENOID LOCK

LEFT-HAND ENGINE

- A - T/R HYD ACTUATOR
- B - T/R ELECT. HARNESS
- C - AFT MOUNT, AFT FIRE EXT; THREE ELECT. CONN: H.P. AIR, FIRE DETECTOR.

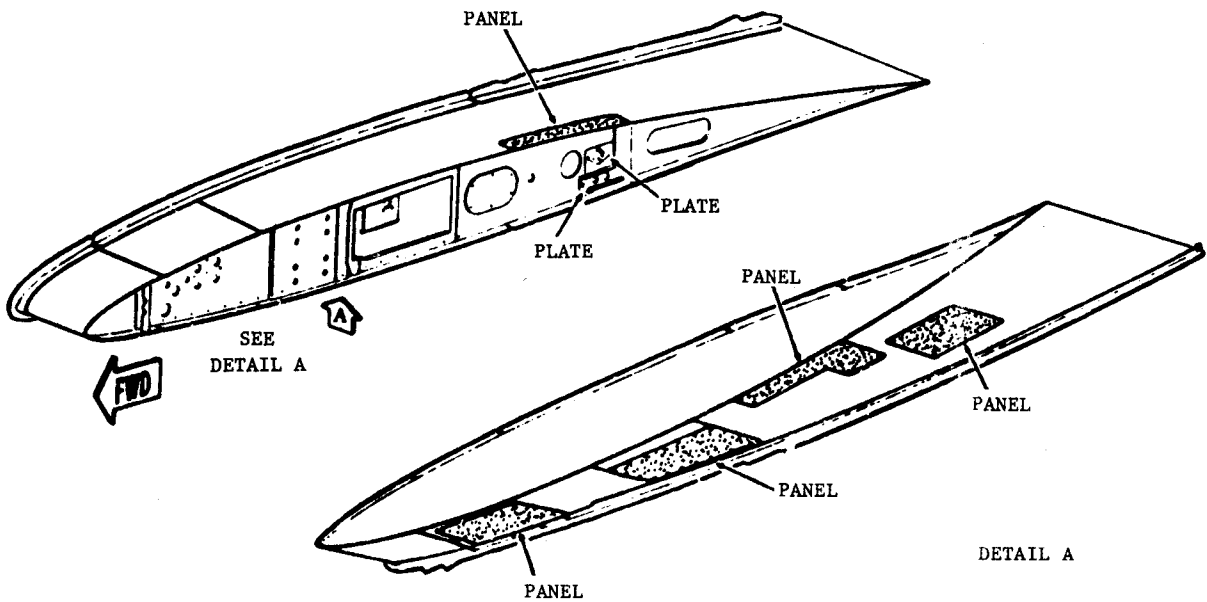

Access Panel Openings

OPERATOR: ED-WES, INC.
 AIRCRAFT NO.: 368
 AIRCRAFT REG.: N368MD

REPORT DATE 09/16/91
 MODEL: 1124A WESTWIND
 ISSUED 07-88 REV. 07-91

WORK COMPLIANCE FORM NO. 55.0101
 CARD NO: 55- 1 OPER01
 050150+ 150 HR INSPECTION

91259
 55-001
 29 29

WORK DUE AT			
DATE	HOURS	LANDINGS	CYCLES
	5028		

RECORD TIME WORK ACCOMPLISHED FOR EACH TASK. KEEP TOP COPY FOR YOUR RECORDS. RETURN CARBON COPY TO CSI FOR UPDATING.

CK CURRENT DUE LIST FOR DUE TIME CHGS PAGE 1

WORK ACCOMPLISHED: DATE: MONTH 1 DAY 22 YEAR 92 AIRCRAFT HOURS: 5020.8 LANDINGS: 2054

TECHNICIAN SIGNATURE: M. W. Withers CERTIFICATE NUMBER: _____

INSPECTED BY: J. D. Miller KIND OF CERTIFICATE: _____

	TECHNICIAN	INSPECTOR	MAN-HOURS
			HRS. THS

550101 INSPECT EMPENNAGE (A)..... MW J.D. _____

550101 INSPECT EMPENNAGE (A) (FOR CAMP OPERATORS, REFER TO ILLUSTRATION ON CARD 55-1. FOR SCAMP OPERATORS, REFER TO MAINTENANCE MANUAL) MECH INSP

R TEXT FROM MM 5-20-06

1. INSPECT RUDDER HINGE POINTS, CHECK ALL BEARINGS FOR LOOSENESS, ROUGHNESS, SAFETY AND GENERAL CONDITION. MW
2. INSPECT RUDDER ATTACH POINTS FOR SECURITY, CRACKS AND GENERAL CONDITION. MW
- R 3. CHECK STOP PADS AND STOP BOLTS FOR CONDITION AND SECURITY. ENSURE THAT TRAVEL STOPS MAKE CONTACT IN BOTH DIRECTIONS OF FULL TRAVEL. MW
4. INSPECT RUDDER TRIM TAB ACTUATOR(S) ATTACH POINTS FOR SECURITY AND GENERAL CONDITION. MW
5. INSPECT TAIL SKID FOR SECURITY AND GENERAL CONDITION. MW
6. INSPECT FRAME STATION 540.00 AND BALLAST AND JACK ADAPTER MOUNTING (IF INSTALLED) FOR CONDITION, DAMAGE AND CORRECT INSTALLATION. MW
7. INSPECT TAIL CONE AND LIGHT FOR CONDITION AND SECURITY. MW
8. CHECK STATIC DISCHARGE WICKS FOR CONDITION AND SECURITY. MW
9. INSPECT ELEVATOR HINGE POINTS FWD AND AFT, CHECK ALL BEARINGS FOR LOOSENESS, ROUGHNESS, SAFETY AND GENERAL CONDITION. INSPECT BONDING JUMPERS FOR CONDITION, FRAYING AND SECURITY. MW
10. INSPECT ELEVATOR TORQUE TUBE FOR CONDITION AND SECURITY OF ATTACH POINTS. MW
11. INSPECT UNIVERSAL JOINTS AND TAPER PINS FOR LOOSENESS AND GENERAL CONDITION. MW
- R 12. CHECK ELEVATOR TRAVEL STOP BOLTS AND STOP PADS FOR SECURITY AND CONDITION. ENSURE THAT TRAVEL STOPS MAKE CONTACT IN BOTH DIRECTIONS OF FULL TRAVEL. MW
13. INSPECT VERTICAL STABILIZER FOR STRUCTURE CONDITION, ATTACH POINTS AND SECURITY. MW
14. INSPECT HORIZONTAL STABILIZER FOR CONDITION AND SECURITY. MW
15. RECORD INSPECTION COMPLIED WITH IN SPACE PROVIDED ON PAGE 1. MW

ISS'D	7-88
REV'D	7-91

**OXYGEN ACCESS
DOOR RH SIDE**

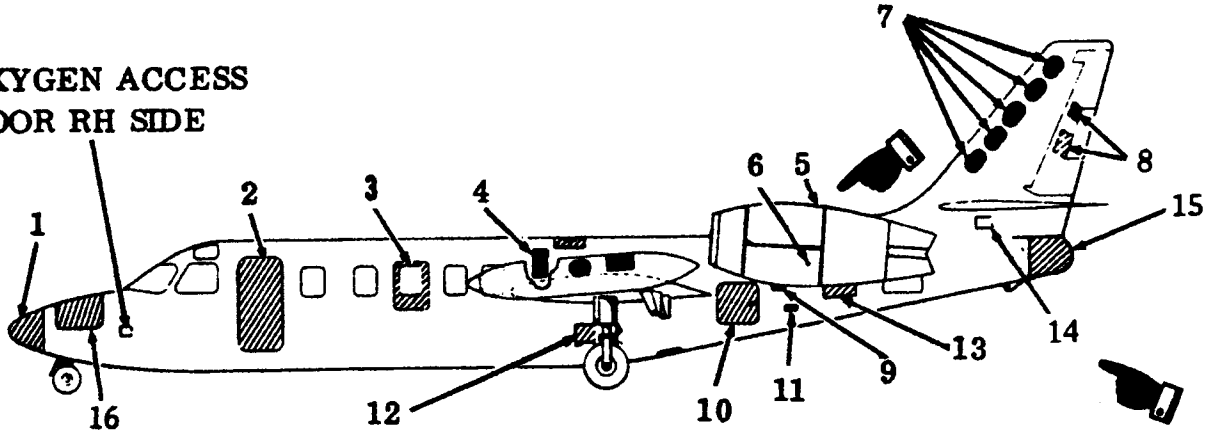

LEFT SIDE VIEW

- | | |
|---|---|
| <ol style="list-style-type: none"> 1. RADOME 2. ENTRANCE DOOR 3. EMERGENCY EXIT 4. AFT PRESSURE BLKHD ELECTRICAL
PLUG ACCESS COVERS 5. UPPER COWL PANEL 6. LOWER COWL DOOR 7. VERTICAL STABILIZER STRUCTURE
INSP. PLATES 8. RUDDER TRIM TAB INSP. COVERS 9. HYD. & NIT. PRESSURE GAGES
ACCESS DOOR | <ol style="list-style-type: none"> 10. MAIN BAGGAGE DOOR 11. EXTERNAL POWER ACCESS DOOR 12. LOWER FUS. FUEL TANK
ACCESS COVERS (LH AND RH) 13. REAR BAGGAGE DOOR 14. HORIZ. STAB. TRIM ACTUATOR
(ALSO RH SIDE) 15. TAIL CONE 16. NOSE COMPARTMENT COVER
(RIGHT AND LEFT) |
|---|---|

Location of Inspection Openings and Access Doors

1124

55-1

OPERATOR: ED-WES, INC.
 AIRCRAFT NO.: 368
 AIRCRAFT REG.: N368MD

REPORT DATE 09/16/91
 MODEL: 1124A WESTWIND
 ISSUED 08-89 REV. 07-91

WORK COMPLIANCE FORM NO. 57.0101
 CARD NO: 57- 1 OPER01

050150+ 150 HR INSPECTION

RECORD TIME WORK ACCOMPLISHED FOR EACH TASK. KEEP TOP COPY FOR YOUR RECORDS. RETURN CARBON COPY TO CSI FOR UPDATING.

91259	WORK DUE AT	* = APU HRS		
57-001	DATE	HOURS	LANDINGS	CYCLES
29 29		3028		

CK CURRENT DUE LIST FOR DUE TIME CHGS PAGE 1

WORK ACCOMPLISHED: DATE: MONTH 01 DAY 21 YEAR 92 AIRCRAFT HOURS: 5020.8 LANDINGS: 3654

TECHNICIAN SIGNATURE: [Signature] CERTIFICATE NUMBER: _____

INSPECTED BY: [Signature] KIND OF CERTIFICATE: _____

	TECHNICIAN	INSPECTOR	MAN-HOURS HRS. THS
570101 INSPECT LEFT WING (A).....	<u>P.H.</u>	<u>T.O.O</u>	
570116 INSPECT RIGHT WING (A).....	<u>P.H.</u>	<u>T.O.O</u>	
570101, 570116			

R NOTE: THE FOLLOWING ADDITIONAL WCF(S) MAY BE REQUIRED TO PERFORM THIS TASK 23.120, 27.230A, 27.280, 27.200B.

ITEM 1 - INSPECT WINGS (A) (FOR CAMP OPERATORS, REFER TO ILLUSTRATION ON CARD 57-1. FOR SCAMP OPERATORS, MECH INSP REFER TO MAINTENANCE MANUAL)

R CONSUMABLES: LPS-3 OR EQUIVALENT
 R TEXT FROM MM 5-20-03
 R

1. INSPECT WING FLAPS FOR SECURITY, CRACKS, LOOSE RIVETS AND CONDITION OF SKIN.
2. INSPECT ATTACH POINTS, HINGES AND BEARINGS FOR GENERAL CONDITION, SECURITY AND CRACKS.
3. INSPECT ATTACH POINTS, BONDING JUMPERS FOR CONDITION, FRAYING AND SECURITY.
4. INSPECT FLEXIBLE DRIVE SHAFTS FOR COUPLING NUTS SECURITY, ROUTING AND STRUCTURE CLEARANCE. FOR CAMP OPERATORS REFER TO WORK COMPLIANCE FORM 27.230A. FOR SCAMP OPERATORS, REFER TO MM 27-50-00.
5. INSPECT FLAP ACTUATING JACKS, ATTACH POINTS, ELECTRICAL CONNECTIONS, RIGGING AND MICROSWITCH SLIDERS FOR SECURITY AND GENERAL CONDITION.
6. INSPECT FLAP POSITION TRANSMITTER POTENTIOMETER, ATTACH POINTS AND ELECTRICAL CONNECTIONS FOR SECURITY AND CONDITION.
7. CHECK FLAP VANE SEGMENTS CONDITION FOR FAILED OR LOOSE FASTENERS AND SECURITY OF ATTACH PLATE. FOR CAMP OPERATORS, REFER TO WORK COMPLIANCE FORM 27.200B. FOR SCAMP OPERATORS, REFER TO MM 27-50-00.
8. INSPECT AILERON FOR SECURITY AND CONDITION.
9. INSPECT AILERON SKIN FOR CONDITION AND LOOSE RIVETS.
10. INSPECT TORQUE TRANSFER TUBES FOR SECURITY OF ATTACHMENT AND SAFETY.
11. CHECK AILERON TRIM TABS TO ACTUATOR ATTACH POINTS AND ELECTRICAL CONNECTIONS FOR SECURITY AND CONDITION.
12. INSPECT AILERON HINGE POINTS, CHECK ALL BEARINGS FOR LOOSENESS, ROUGHNESS, SAFETY AND GENERAL CONDITION.
13. LUBRICATE PUSH-PULL TUBE ROLLER GUIDES (ROLLER AND TUBE) WITH LPS-3 OR EQUIVALENT.
14. LUBRICATE TRIM TAB AND SERVO TAB HINGES FROM INSIDE WITH LPS-3 OR EQUIVALENT.
15. CHECK NON-ICING FUEL VENT FOR OBSTRUCTIONS AND FUEL LEAKAGE.
16. INSPECT TIP TANK AND WING FILLET FOR CONDITION, SECURITY AND FUEL LEAKS.
17. INSPECT TIP TANK NAVIGATION LIGHT LENS FOR CRACKS, SECURITY AND CONDITION. (POSITION AND STROBE.)
18. INSPECT LANDING LIGHT LENS AND LIGHT FOR SECURITY AND CONDITION.
19. CHECK DRAIN HOLES FOR CLEANLINESS.
20. PERFORM STATIC DISCHARGE WICK RESISTANCE CHECK (AILERONS AND TIP TANKS) (REFER TO WORK COMPLIANCE FORM 23.120).
21. INSPECT LOWER SURFACE OF WING SKIN FOR CRACKS, SCRATCHES, LOOSE RIVETS, AND VORTEX GENERATORS FOR SECURITY AND CONDITION.
22. CHECK CONDITION OF LEADING EDGE PNEUMATIC DE-ICER BOOT.
23. CHECK FUEL TANK DRAINS FOR CONDITION AND LEAKAGE.
24. INSPECT WING SKIN FOR CRACKS, SCRATCHES, LOOSE RIVETS, FUEL LEAKAGE AND GENERAL CONDITION.
25. CHECK ALL PLUMBING ATTACHED ALONG WING REAR SPAR FOR PROPER ROUTING SECURITY, CONDITION AND LEAKS.

[Handwritten initials and marks on the right margin]

NOTE: CHECK FOR CLEARANCE BETWEEN FLUID LINES AND FLAP FLEX DRIVE CABLES AND AILERON TORQUE TUBES WHILE FLAPS AND AILERONS ARE MOVED THROUGH FULL TRAVEL.

OPERATOR: ED-WES, INC.

REPORT DATE 09/16/91

WORK COMPLIANCE FORM NO.

57.0101

AIRCRAFT NO.: 368

MODEL: 1124A WESTWIND (CONTINUED)

CARD NO: 57- 1

OPER01

AIRCRAFT REG.: N368MD

ISSUED 08-89 REV. 07-91

050150+ 150 HR INSPECTION

91259

WORK DUE AT

* = APU HRS

RECORD TIME WORK ACCOMPLISHED FOR EACH TASK. KEEP TOP COPY FOR YOUR RECORDS. RETURN CARBON COPY TO CSI FOR UPDATING.

57-001

DATE

HOURS

LANDINGS

CYCLES

29 29

3028

CK CURRENT DUE LIST FOR DUE TIME CHGS

PAGE 2

- 26. CHECK WIRE BUNDLES ENTERING THE WING FROM THE AFT FUSELAGE FOR DAMAGE, CHAFING AND SECURITY.
- 27. INSPECT WING FAIRINGS FOR SECURITY, CRACKS AND GENERAL CONDITION.
- 28. CHECK SPEED BRAKES AND LIFT DUMPERS FOR CONDITION, SECURITY AND HYDRAULIC FLUID LEAKAGE AND INSPECT RIGHT-HAND OUTBOARD MICROSWITCH FOR SECURITY. FOR CAMP OPERATORS, REFER TO WORK COMPLIANCE FORM 27.280. FOR SCAMP OPERATORS, REFER TO MM 27-60-00.
- 29. RECORD INSPECTION COMPLIED WITH IN SPACE PROVIDED ON PAGE 1.

D.V.
2/11

R

ISS'D	7-88
REV'D	

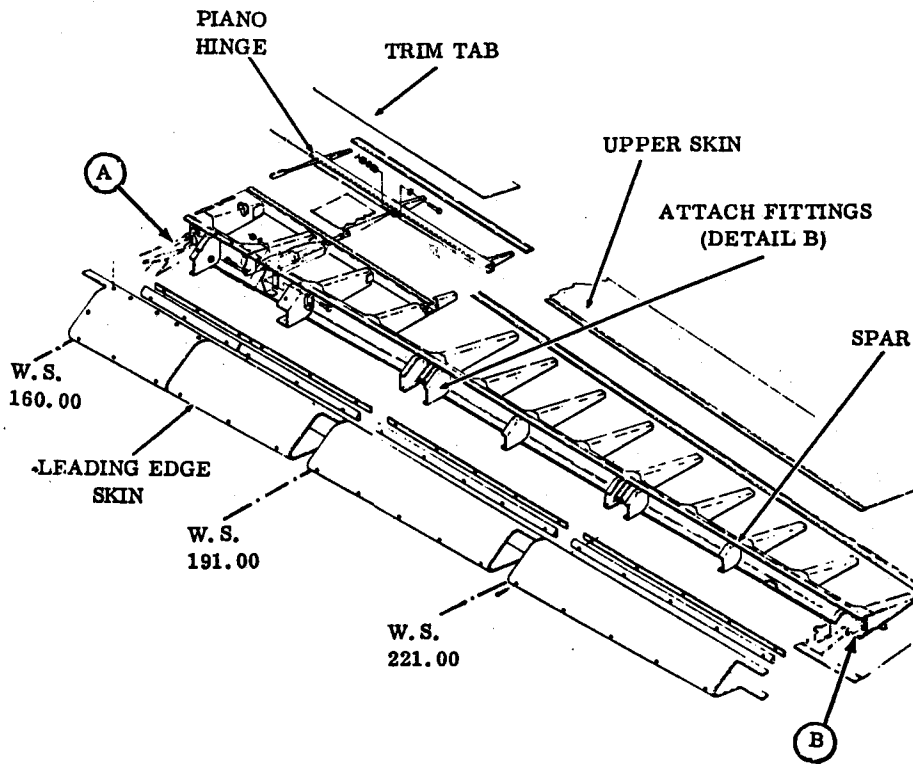
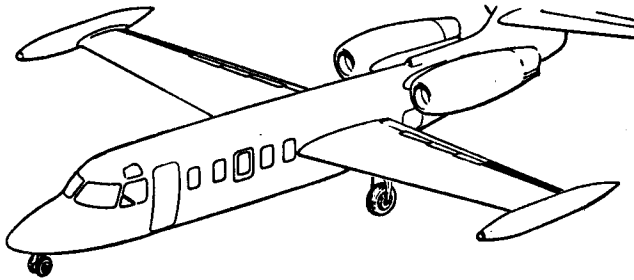

Access Panels to Be Opened For Inspection

(Continued on next page.)

ISS'D	7-88
REV'D	

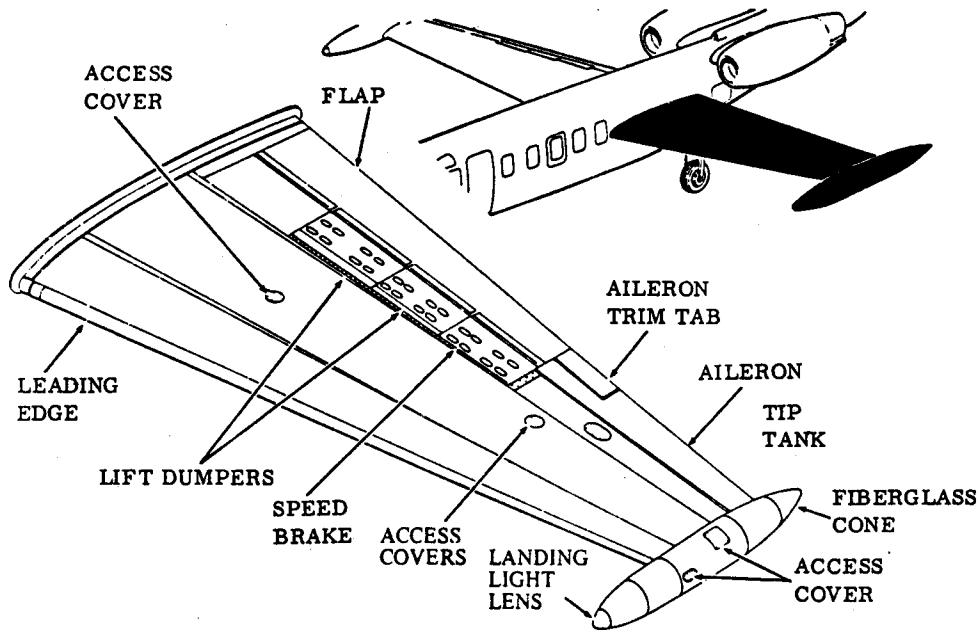

TOP VIEW
LEFT WING SHOWN, RIGHT WING
OPPOSITE, EXCEPT AILERON TRIM TAB.

BOTTOM VIEW
LEFT WING SHOWN, RIGHT WING
OPPOSITE, EXCEPT AILERON
TRIM TAB:

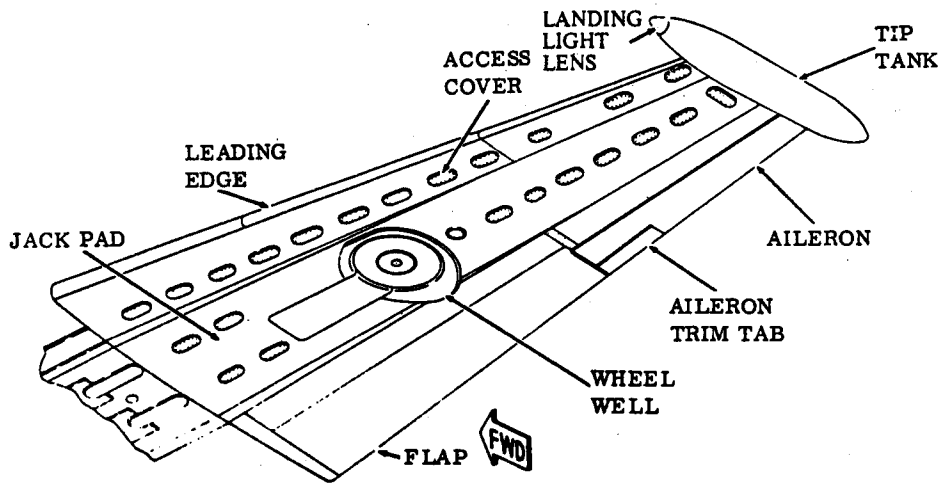

Access Panels To Be Opened For Inspection (Cont'd.)

OPERATOR: ED-WES, INC.
 AIRCRAFT NO.: 368
 AIRCRAFT REG.: N368MD

REPORT DATE 09/16/91
 MODEL: 1124A WESTWIND
 ISSUED 07-88 REV. 07-91

WORK COMPLIANCE FORM NO. 57.020
 OPER01

91259	WORK DUE AT	* = APU HRS			050150+ 130 HR INSPECTION
57-002	DATE	HOURS	LANDINGS	CYCLES	RECORD TIME WORK ACCOMPLISHED FOR EACH TASK. KEEP TOP COPY FOR YOUR RECORDS. RETURN CARBON COPY TO CSI FOR UPDATING.
29 29		5028			CK CURRENT DUE LIST FOR DUE TIME CHGS PAGE 1

WORK ACCOMPLISHED: DATE: MONTH 01 DAY 22 YEAR 92 AIRCRAFT HOURS: 5020.9 LANDINGS: 2654

TECHNICIAN SIGNATURE: Pat Hoffart CERTIFICATE NUMBER: _____

INSPECTED BY: L O Druef KIND OF CERTIFICATE: _____

	TECHNICIAN	INSPECTOR	MAN-HOURS
			HRS. TNS
570106 INSPECT LEFT AILERON BELLCRANK...MM 5-20-03.....	<u>ff</u>		
570120 INSPECT RIGHT AILERON BELLCRANK...MM 5-20-03.....	<u>ff</u>		

- *****
- 570106, 570120
 INSPECT AILERON BELLCRANK
- R 1. INSPECT AILERON BELLCRANK TRAVEL STOPS AND ATTACH POINTS FOR SAFETY, GENERAL CONDITION AND SECURITY. ENSURE THAT TRAVEL STOPS MAKE CONTACT IN BOTH DIRECTIONS OF FULL TRAVEL.
- R 2. RECORD INSPECTION COMPLIED WITH IN SPACE PROVIDED ON PAGE 1.

OPERATOR: ED-WEB, INC.
AIRCRAFT NO.: 368
AIRCRAFT REG.: N368MD

REPORT DATE 09/16/91
MODEL: 1124A WESTWIND (CONTINUED)

WORK COMPLIANCE FORM NO. 71.0201

CARD NO: 71- 2 OPER01

ISSUED 07-88 REV. 07-91 050150+ 150 HR INSPECTION

RECORD TIME WORK ACCOMPLISHED FOR EACH TASK. KEEP TOP COPY FOR YOUR RECORDS. RETURN CARBON COPY TO CSI FOR UPDATING.

91259
71-001
29 29

WORK DUE AT		* = APU HRS	
DATE	HOURS	LANDINGS	CYCLES
	5028		

CK CURRENT DUE LIST FOR DUE TIME CHGS PAGE 2

C. ALL STEPS A. THROUGH B. COMPLETED.

12. CHECK INDICATOR PIN ON OIL FILTER BY-PASS INDICATOR VALVE AS FOLLOWS: (REFER TO ILLUSTRATION) (CAMP ONLY).

A. IF PIN IS EXTENDED, RESET PIN AND PERFORM THE FOLLOWING PROCEDURES.

- (1) CHECK MAGNETIC PLUG OF CHIP DETECTOR. FOR CAMP OPERATORS, REFER TO WORK COMPLIANCE FORM 79.120, FOR SCAMP OPERATORS, REFER TO SM 72-00-00, CHIP DETECTOR INSPECTION.
- (2) REMOVE, INSPECT AND REPLACE OIL FILTER. FOR CAMP OPERATORS, REFER TO WORK COMPLIANCE FORM 79.110, FOR SCAMP OPERATORS, REFER TO SM 72-00-00, OIL FILTER INSPECTION.
- (3) PERFORM SOAP CHECK AND FORWARD OIL SAMPLE AND REMOVED OIL FILTER TO APPROVED SOAP LABORATORY. (FOR CAMP OPERATORS, REFER TO WORK COMPLIANCE FORM 79.100, FOR SCAMP OPERATORS, REFER TO SM 72-00-00) SPECTROMETRIC OIL ANALYSIS PROGRAM (SOAP) CHECK.
- (4) INSPECT INTERIOR OF TRANSFER GEARBOX FOR METAL PARTICLES.

B. STEP A. COMPLETED.

13. VISUALLY CHECK BRACKETS AND SUPPORTS FOR DAMAGE THAT WOULD IMPAIR FUNCTION OR ASSEMBLY. REFER TO LIGHT MAINTENANCE MANUAL INSTRUCTIONS FOR PERFORMING A VIBRATION CHECK ANY TIME EVIDENCE INDICATES POSSIBLE EXCESSIVE ENGINE VIBRATION (CRACKED BRACKET OR SUPPORTS).

TEXT FROM MM 5-20-07

- 14. INSPECT P2 T2 SENSOR FOR SECURITY AND CONDITION.
- 15. INSPECT COWL STRUCTURE AND SKIN FOR DENTS, CRACKS, FIT AND GENERAL CONDITION.
- 16. INSPECT DOORS AND LATCHES FOR DENTS, CRACKS, FIT, GENERAL CONDITION AND OPERATION.
- 17. INSPECT FIRE DETECTOR ELEMENT FOR CHAFING, KINKS, SECURITY AND GENERAL CONDITION.
- 18. INSPECT LOW-PRESSURE BLEED DUCT FOR LEAKS, CRACKS, FIT AND GENERAL CONDITION.
- 19. INSPECT HIGH-PRESSURE BLEED DUCT FOR LEAKS, CRACKS, FIT AND GENERAL CONDITION.

NOTE: INSPECT MANIFOLD ASSEMBLY DURING ENGINE PERIODIC INSPECTION OR WHENEVER THE AFTER BODY IS REMOVED.

- R20. INSPECT THE STARTER-GENERATOR, ELECTRICAL LEADS AND COOLING DUCT FOR INSTALLATION, LEAKS, CLAMPING, SECURITY AND SAFETY.
- R21. INSPECT FUEL LINES FOR LEAKS, CLAMPING AND SECURITY, FUEL FLOW TRANSMITTER FOR INSTALLATION, SECURITY AND SAFETY, AND PRESSURE SWITCH FOR INSTALLATION, SECURITY AND SAFETY.
- R22. INSPECT HYDRAULIC LINES FOR LEAKS, CLAMPING AND SECURITY, ATTENUATOR FOR INSTALLATION, SECURITY AND SAFETY, HYDRAULIC PUMP FOR INSTALLATION, LEAKS, SECURITY AND SAFETY, AND QUICK-DISCONNECTS FOR INSTALLATION, SECURITY AND SAFETY.
- 23. INSPECT HYDRAULIC PUMP. REMOVE DRIVE SPLINE, INSPECT AND LUBRICATE. REFER TO MM 29-10-00, INSPECTION/CHECK.
- R24. INSPECT OIL PRESSURE LINES FOR LEAKS, CLAMPING AND SECURITY, PRESSURE TRANSMITTER FOR SECURITY, INSTALLATION AND SAFETY, AND LOW-PRESSURE SWITCH FOR SECURITY, INSTALLATION AND SAFETY.
- 25. INSPECT ELECTRICAL WIRING CONNECTORS, FOR SECURITY AND GENERAL CONDITION.
- 26. VISUALLY INSPECT JET TAIL PIPE NOZZLES FOR DENTS, CRACKS, BULGES AND GENERAL CONDITION.
- 27. RECORD INSPECTION COMPLIED WITH IN SPACE PROVIDED ON PAGE 1.

Handwritten notes and signatures on the right margin, including 'EAB' and 'JAD' at the top, and 'EAB' and 'JAD' at the bottom.

ISS'D	7-88
REV'D	

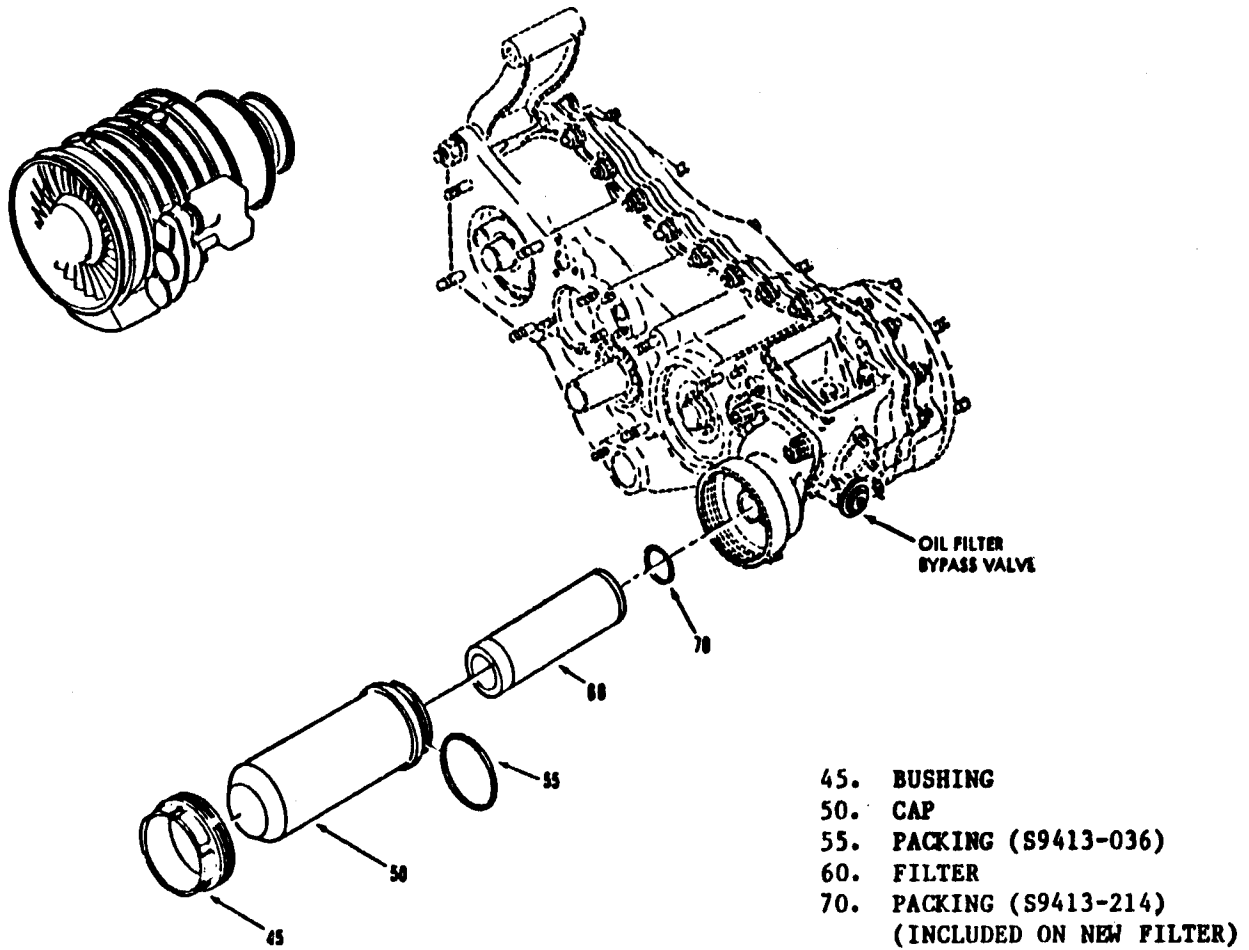

Oil Filter By-pass Indicator Valves, and Oil Filter

1124

71-2

OPERATOR: ED-WES, INC.
 AIRCRAFT NO.: 368
 AIRCRAFT REG.: N368MD

REPORT DATE 09/16/91
 MODEL: 1124A WESTWIND
 ISSUED 07-88 REV. 01-89

WORK COMPLIANCE FORM NO. 79.100
 OPER01
 050150+ 150 HR INSPECTION

91259
 79-008
 29 29

WORK DUE AT		* = APU HRS.	
DATE	HOURS	LANDINGS	CYCLES
	5028		

RECORD TIME WORK ACCOMPLISHED FOR EACH TASK. KEEP TOP COPY FOR YOUR RECORDS. RETURN CARBON COPY TO CSI FOR UPDATING.

CK CURRENT DUE LIST FOR DUE TIME CHGS PAGE 1

WORK ACCOMPLISHED: DATE: MONTH 1 DAY 23 YEAR 92 AIRCRAFT HOURS: 5020.8 LANDINGS: 3654

TECHNICIAN SIGNATURE: E.L.B. CERTIFICATE NUMBER: _____

INSPECTED BY: [Signature] KIND OF CERTIFICATE: _____

	TECHNICIAN	INSPECTOR	MAN-HOURS HRS. THS
(790116) () SOAP CHECK LEFT ENGINE...ENG SM 72-00-00.....	<u>E.L.B.</u>		
RECORD FREQUENCY OF NEXT SOAP CHECK HOURS _____			
(791616) () SOAP CHECK RIGHT ENGINE...ENG SM 72-00-00.....	<u>P.M.M.</u>		
RECORD FREQUENCY OF NEXT SOAP CHECK HOURS _____			

790116, 791616
 SOAP CHECK ENGINE

CONSUMABLES: SAMPLING KIT P/N 294199-1

1. POSITION DRIP PAN UNDER ENGINE TO CATCH ANY SPILLED OIL.

CAUTION: WHEN TAKING OIL SAMPLE FROM ENGINE FOR SOAP CHECK, ENSURE ALL EQUIPMENT USED IS CLEAN AND NOT CONTAMINATED TO PREVENT OBTAINING FALSE INDICATION OF OIL CONTAMINATION.

NOTE: 1. WHENEVER LEAKAGE OF FUEL INTO THE OIL SYSTEM IS SUSPECTED (ODOR OF FUEL DETECTED IN OIL OR OIL LEVEL INCREASING), PERFORM FUEL-IN-OIL INSPECTION.
 2. WEAR OF INTERNAL ENGINE PARTS IS NOT ALWAYS DETECTED BY SPECTROMETRIC ANALYSIS OF THE OIL SAMPLE ALONE. THEREFORE, IT IS ALSO VERY IMPORTANT TO INSPECT THE OIL FILTER FOR TRAPPED METALLIC PARTICLES THAT CAN PROVIDE IMPORTANT INFORMATION AS TO THE SOURCE OF SUCH MATERIAL.

- SIPHON AN OIL SAMPLE FROM THE ENGINE OIL TANK AT THE FILLER CAP USING PLASTIC TUBE PROVIDED IN SAMPLING KIT. ROUTE THE PLASTIC TUBE INTO THE SMALL CONTAINER PROVIDED IN THE SAMPLING KIT TO CONTAIN THE OIL SAMPLE.
- REMOVE OIL FILTER FROM ENGINE.
- VISUALLY INSPECT OIL FILTER. IF AN ABNORMAL NUMBER OF TRAPPED PARTICLES IS EVIDENT, CONTACT A GARRETT FIELD SERVICE ENGINEER FOR GUIDANCE AND FURTHER INSTRUCTIONS.
- PLACE OIL FILTER IN CONTAINER SUPPLIED IN SAMPLING KIT.
- INSTALL REPLACEMENT OIL FILTER ON ENGINE.

CAUTION: ENSURE THAT CONTAINERS (SMALL CONTAINER FOR SOAP SAMPLE AND LARGE CONTAINER FOR OIL FILTER) ARE PROPERLY SEALED TO PREVENT LEAKAGE DURING SHIPMENT.

NOTE: A LIST OF GARRETT AUTHORIZED LABORATORIES FOR OIL ANALYSIS IS GIVEN IN BIL (SERVICE INFORMATION LETTER) 7731-34.

- PREPARE AND ROUTE SAMPLING KIT IN ACCORDANCE WITH SAMPLING KIT INSTRUCTIONS.
- RECORD CHECK COMPLIED WITH IN SPACE PROVIDED ON PAGE 1.

OPERATOR: ED-WES, INC.
 AIRCRAFT NO.: 368
 AIRCRAFT REG.: N368MD

REPORT DATE 09/16/91
 MODEL: 1124A WESTWIND
 ISSUED 07-88 REV.

WORK COMPLIANCE FORM NO. 79.120
 OPER01

91259
 79-010
 29 29

WORK DUE AT	* = APU HRS	RECORD TIME WORK ACCOMPLISHED FOR EACH TASK. KEEP TOP COPY FOR YOUR RECORDS. RETURN CARBON COPY TO CSI FOR UPDATING.
DATE	HOURS	LANDINGS
	5028	

050150+ 130 HR INSPECTION
 CK CURRENT DUE LIST FOR DUE TIME CHGS

PAGE 1

WORK ACCOMPLISHED: DATE: MONTH 1 DAY 23 YEAR 92 AIRCRAFT HOURS: 5020.8 LANDINGS: 3654

TECHNICIAN SIGNATURE: _____ CERTIFICATE NUMBER: _____

INSPECTED BY: [Signature] KIND OF CERTIFICATE: _____

	TECHNICIAN	INSPECTOR	MAN-HOURS HRS.THS
790126 INSPECT LEFT ENGINE CHIP DETECTOR...ENG SM 72-00-00.....	<u>[Signature]</u>		
791626 INSPECT RIGHT ENGINE CHIP DETECTOR...ENG SM 72-00-00.....	<u>[Signature]</u>		
790126, 791626			

NOTE: THE FOLLOWING ADDITIONAL WCF(S) ARE REQUIRED TO PERFORM THIS TASK 79.100, 79.110.

INSPECT ENGINE CHIP DETECTOR

EQUIPMENT/CONSUMABLES: PACKING P/N 89413-357, PACKING P/N 89413-012, TORQUE WRENCH 0 TO 40 INCH-POUNDS, PACKING P/N 89413-236, TRICHLOROTRIFLUOROETHANE SOLVENT (MS 180 FREON)

1. REMOVE MAGNETIC PLUG.
2. HOLD CHECK VALVE HOUSING WITH WRENCH. USE SECOND WRENCH TO REMOVE MAGNETIC PLUG. DISCARD PACKING.
3. CHECK MAGNETIC PLUG FOR METAL PARTICLES.
4. IF METAL PARTICLES ARE EVIDENT, PERFORM THE FOLLOWING PROCEDURES.
 - A. RESET PIN ON OIL FILTER BY-PASS VALVE IF EXTENDED.
 - B. REMOVE, INSPECT AND REPLACE OIL FILTER. REFER TO WORK COMPLIANCE FORM 79.100
 - C. PERFORM SOAP CHECK. REFER TO WORK COMPLIANCE FORM 79.110.
 - D. INSPECT TRANSFER GEARBOX FOR METAL PARTICLES IN ACCORDANCE WITH THE FOLLOWING PROCEDURES.
 - (1) REMOVE NUTS, WASHER AND COVER.
 - (2) REMOVE AND DISCARD PACKING.
 - (3) CHECK BEVEL GEAR TEETH. THERE SHALL BE NO ABNORMAL WEAR PATTERN, EXCESSIVE WEAR, OR CHIPPED OR BROKEN TEETH. REPLACE TRANSFER GEARBOX IF REQUIREMENTS ARE NOT MET.
 - (4) CHECK INTERIOR OF TRANSFER GEARBOX FOR METAL PARTICLES. IF METAL PARTICLES ARE PRESENT, CHECK FOR SOURCE AND REPAIR.
 - (5) INSTALL NEW PACKING P/N 89413-236 ON COVER.
 - (6) INSTALL COVER AND SECURE WITH WASHERS AND NUTS.
 - (7) TORQUE NUTS TO 30 INCH-POUNDS.
5. IF METAL PARTICLES ARE EVIDENT ON MAGNETIC PLUG ONLY, NONE IN OIL FILTER OR TRANSFER GEARBOX, PERFORM THE FOLLOWING PROCEDURES.
 - A. CLEAN MAGNETIC PLUG, AND REINSTALL MAGNETIC PLUG. (REFER TO STEPS 6 AND 7.)
 - B. RUN ENGINE THROUGHOUT FULL POWER RANGE IN ACCORDANCE WITH AIRCRAFT FLIGHT MANUAL AND/OR APPROPRIATE AIRCRAFT DOCUMENT FOR 15 MINUTES. (IN COLD WEATHER OPERATION, RUN ENGINE MORE THAN 15 MINUTES IF REQUIRED TO OBTAIN MINIMUM OIL TEMPERATURE OF 4 DEGREES C (40 DEGREES F). DETERMINE IF ENGINE IS ACCEPTABLE FOR CONTINUED OPERATION (RUN DID NOT PRODUCE RECURRENCE OF INITIAL INDICATION) BY REPEATING MAGNETIC PLUG, OIL FILTER BY-PASS INDICATOR VALVE, SOAP AND TRANSFER GEARBOX INSPECTIONS.
 - C. UPON REACHING THREE TO FIVE HOURS OF ENGINE OPERATION FOLLOWING ENGINE RUN AND CHECKS IN PREVIOUS STEP, REPEAT MAGNETIC PLUG, OIL FILTER BY-PASS INDICATOR VALVE, SOAP, AND TRANSFER GEARBOX INSPECTIONS.
6. INSTALL NEW PACKING P/N 89413-012 ON MAGNETIC PLUG.
7. INSTALL MAGNETIC PLUG IN CHECK VALVE HOUSING. HOLD CHECK VALVE HOUSING WITH WRENCH, AND USING A SECOND WRENCH, TORQUE MAGNETIC PLUG TO 20 INCH-POUNDS AND LOCKWIRE.
8. RECORD INSPECTION COMPLIED WITH IN SPACE PROVIDED ON PAGE 1.

OPERATOR: ED-WES, INC.
 AIRCRAFT NO.: 368
 AIRCRAFT REG.: N368MD

REPORT DATE 09/16/91
 MODEL: 1124A WESTWIND

WORK COMPLIANCE FORM NO. 95.030
 CARD NO: 95- 2 OPER01
 030150+ 150 HR INSPECTION

91259
 95-006
 29 29

WORK DUE AT			
DATE	HOURS	LANDINGS	CYCLES
	3028		

RECORD TIME WORK ACCOMPLISHED FOR EACH TASK. KEEP TOP COPY FOR YOUR RECORDS. RETURN CARBON COPY TO CSI FOR UPDATING.

CK CURRENT DUE LIST FOR DUE TIME CHGS PAGE 1

WORK ACCOMPLISHED: DATE: MONTH 1 DAY 22 YEAR 92 AIRCRAFT HOURS: 5020.8 LANDINGS: 3654

TECHNICIAN SIGNATURE: EJ Bayet CERTIFICATE NUMBER: _____

INSPECTED BY: GO Dmily KIND OF CERTIFICATE: _____

TECHNICIAN INSPECTOR MAN-HOURS
 HRS.THS

(950300) () INSPECT NACELLE COWLS...BL NO. WW-2450B..... EJB

750300
 INSPECT NACELLE COWLS (REFER TO ILLUSTRATION ON CARD 95-2)

R EQUIPMENT/CONSUMABLES: BORESCOPE MODEL BF, TYPE 3C3 WITH A COLD LIGHT POWER MODEL LK4 OR EQUIVALENT (OLYMPUS CORP,
 R OF AMERICA) HUCK MODEL 200 RIVET GUN, OR EQUIVALENT; DEBURRING TOOL, GAC P/N 3491-1963-114 OR
 R EQUIVALENT

NOTE: THE FOLLOWING PROCEDURES SHALL BE ACCOMPLISHED ON BOTH NACELLES.

1. TURN OFF ELECTRICAL POWER, DISCONNECT AIRCRAFT BATTERIES.
2. WITH INLET IN PLACE, INSPECT ANTI-ICING AIR PASSAGE RIVETS IN AREA DEFINED IN ILLUSTRATION.

NOTE: A DARK MARK OR STAIN ORIGINATING FROM THE RIVET HEAD WILL INDICATE EITHER A LOOSE RIVET, OR A RIVET WHOSE HEAD PROTRUDES ABOVE OR BELOW THE SURFACE. DO NOT CLEAR STREAKS UNTIL ALL SUSPECT RIVETS HAVE BEEN CHECKED AS OUTLINED BELOW.

3. PERFORM THE FOLLOWING CHECKS IN SEQUENCE: IF A RIVET IS DETERMINED TO BE LOOSE, USING TECHNIQUES OF A. AND/OR B. BELOW, MARK FOR REFERENCE WITH GREASE PENCIL AND PROCEED TO NEXT STEP.
 - A. PRESS RIVET WITH THUMBNAIL OR TOOL SUCH AS AWL TO DETERMINE IF THERE IS ANY RELATIVE MOTION OR ROTATION BETWEEN RIVET AND SKIN. IF LOOSENESS IS IN DOUBT PROCEED TO NEXT STEP.
 - B. DIRECT FLASHLIGHT ON RIVET HEAD AND APPLY DOWNWARD FORCE WITH A DULL AWL, FIRST AT CENTER OF RIVET HEAD AND THEN AT A MINIMUM OF THREE POINTS NEAR PERIPHERY. OBSERVE FOR ANY RIVET MOTION.
4. IF NO LOOSE OR MISSING RIVETS ARE FOUND, RETURN THE AIRCRAFT TO SERVICE.
5. IF LOOSE AND/OR MISSING RIVETS ARE FOUND ON NACELLE INLET P/N F10A5B20201-X, CONTINUE TO STEP 7.

NOTE: DO NOT ATTEMPT TO REPLACE LOOSE OR MISSING RIVETS.

6. IF LOOSE AND/OR MISSING RIVETS ARE FOUND IN THE LEADING EDGE ON NACELLE INLETS P/N F10A5B50201-X OR P/N F10A5RDB50201-X, REFER TO GRUMMAN AEROSPACE MAINTENANCE BULLETIN (GAC-002-084, DATED 5-7-84) FOR LIMITATIONS AND REPAIR PROCEDURES. IF LOOSE AND/OR MISSING RIVETS ARE FOUND ON THE ABOVE ASSEMBLIES IN AREAS OTHER THAN THE LEADING EDGE, CONTACT AN IAII TECHNICAL REPRESENTATIVE.

NOTE: GRUMMAN AEROSPACE MAINTENANCE BULLETIN IS ATTACHED TO S.L.WW-2450B.

7. CHECK THE MID-FRAME FOR CRACKS, UTILIZING THE BORESCOPE SPECIFIED OR AN EQUIVALENT BY INSERTING THE BORESCOPE THROUGH THE VENTS. THE PATH OF EACH INSERTION IS SHOWN BY THE HEAVY DASHED LINES AS NOTED ON ILLUSTRATION. RECORD ANY CRACKS OBSERVED.

NOTE: TO INSPECT FLANGE FOR CRACKS, INSERT BORESCOPE THROUGH LIGHTENING HOLE. CHECK FLANGE FOR CRACKS BETWEEN RIVETS AND FROM RIVETS AFT TO FLANGE BEND RADIUS. REFER TO TABLE FOR NACELLE INLET COWL DISPOSITION.

TABLE

CONDITION	LOOSE RIVETS	FRAME CRACKED	DISPOSITION
1	NO	---	NO FURTHER ACTION REQUIRED. RETURN AIRCRAFT TO SERVICE. REINSPECT AT 150 HOURS.
2	YES	NO	A. IF TWELVE (12) OR MORE DEFECTIVE RIVETS ARE FOUND IN ONE FRAME OR IF SIX (6) OR MORE

OPERATOR: ED-WES, INC.
 AIRCRAFT NO.: 368
 AIRCRAFT REG.: N368MD

REPORT DATE 09/16/91
 MODEL: 1124A WESTWIND (CONTINUED)

WORK COMPLIANCE FORM NO. 95.050
 CARD NO: 95- 2 OPER01

050150+ 150 HR INSPECTION

RECORD TIME WORK ACCOMPLISHED FOR EACH TASK. KEEP TOP COPY FOR YOUR RECORDS. RETURN CARBON COPY TO CSI FOR UPDATING.

91259 95-006 29 29	WORK DUE AT			
	DATE	HOURS	* = APU HRS LANDINGS	CYCLES
		5028		

CK CURRENT DUE LIST FOR DUE TIME CHGS PAGE 2

ADJACENT RIVETS ARE DEFECTIVE PROCEED TO STEP 8.
 B. IF THERE ARE DEFECTIVE RIVETS, BUT NOT EXCEEDING THE CRITERIA OF A ABOVE, THE INLET SHALL BE CONSIDERED ACCEPTABLE FOR FLIGHT WITH A REQUIREMENT TO RECHECK FOR DEFECTIVE RIVETS EVERY 150 HOURS. PROCEED TO STEP 9.

CONDITION	LOOSE RIVETS	FRAME CRACKED
3	YES	YES

DISPOSITION
 A. IF THE MID-FRAME SHOWS FLANGE CRACKING ALONG 50% OR MORE OF THE CIRCUMFERENCE, OR IF THE MID-FRAME IS CRACKED IN TWO (2) PARTS IN ANY AREA, (A FLANGE CRACK THROUGH A LIGHTNING HOLE IS AN EXAMPLE) PROCEED TO STEP 8.
 B. IF THERE ARE DEFECTIVE RIVETS AND CRACKED FRAMES BUT NOT EXCEEDING THE CRITERIA OF 2-A. AND 3-A., THE INLET IS CONSIDERED ACCEPTABLE WITH A REQUIREMENT TO CHECK FOR DEFECTIVE RIVETS AND CRACKED FRAMES EVERY 50 HOURS. PROCEED TO STEP 9.

8. DISPOSITION OF DAMAGED INLETS - THE FOLLOWING COURSE OF ACTION IS RECOMMENDED:
 A. REMOVE DAMAGED MACELLE INLET P/N F10A5B20201-X AND REPLACE WITH SERVICEABLE EXCHANGE UNIT.
 B. IF A. ABOVE IS NOT POSSIBLE AT THIS TIME, THE AIRCRAFT MAY CONTINUE IN SERVICE. HOWEVER, THE OPERATOR MUST PERFORM A PREFLIGHT INSPECTION AND RECORD CHANGE OBSERVED.

NOTE: THE DAMAGED INLET SHOULD BE REPLACED AS SOON AS POSSIBLE.

9. RETURN AIRCRAFT TO SERVICE.

NOTE: GRUMMAN AEROSPACE MAINTENANCE BULLETIN IS ATTACHED TO S.L.NW-2450B.

10. RECORD INSPECTION COMPLIED WITH IN SPACE PROVIDED ON PAGE 1.

ISS'D	7-88
REV'D	

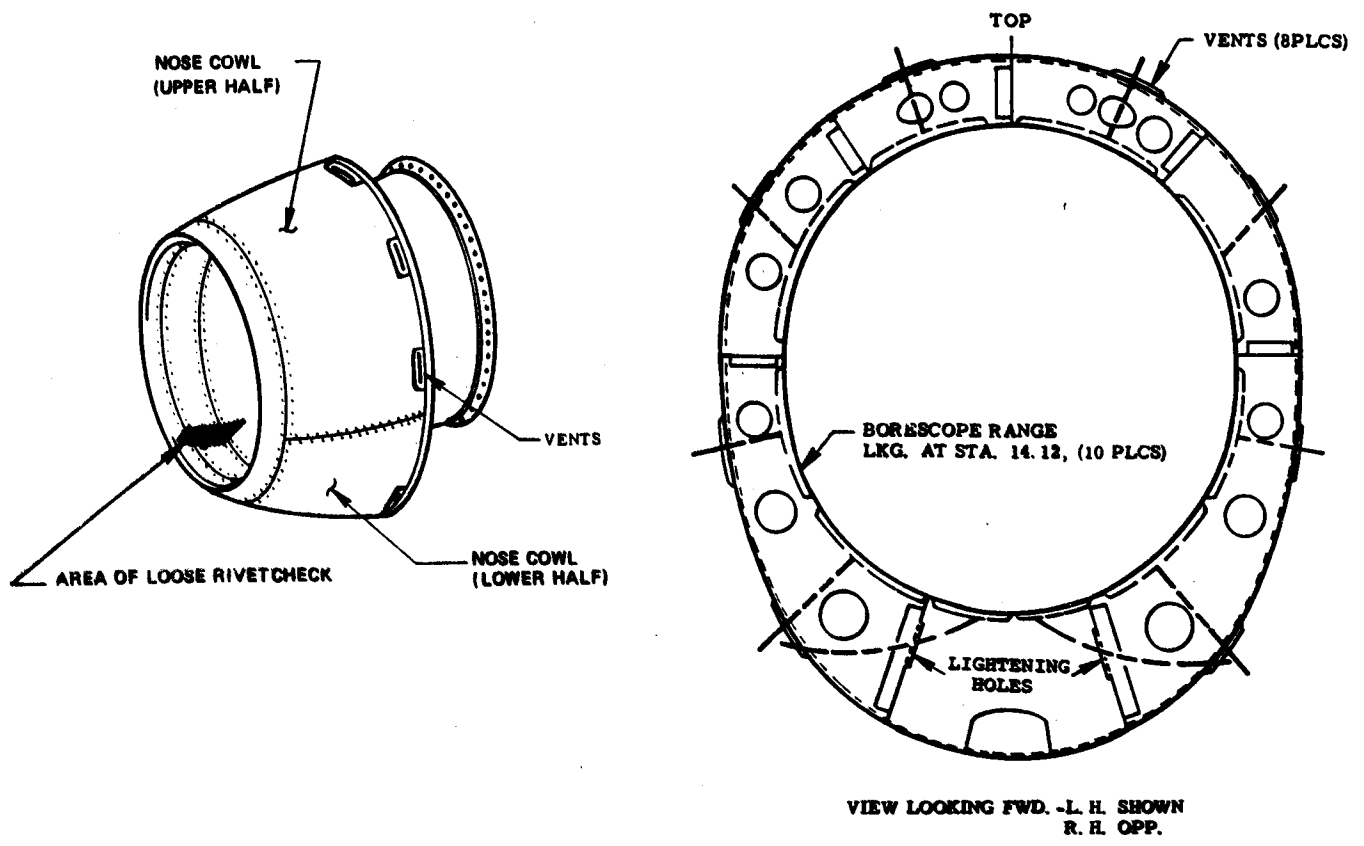

Inspection for Loose Rivets (Nose Cowl Assembly)

4777

7-88